



DIESEL GENSET

MANUAL BOOK

This Manual Book should be read carefully by Genset Operator



www.datrofel.com.tr

POWER
WITH YOU

INDEX

1	INTRO	4	4.15	Engine Oil and Coolant	21
1.1	Group Label	4	4.15.1	Viscosity-Temperature Diagram	21
2	SAFETY	5	4.16	Batteries	21
2.1	General	5	4.16.1	Maintenance Type Batteries	21
2.2	Protective Material Usage	5	4.16.1.1	Charging Acid Water to the Battery	22
2.3	Fire Extinguishers	5	4.16.1.2	Battery Maintenance	22
2.4	Precautions Against Leakage	5	4.16.1.3	Testing the Battery	22
2.5	Pressured Water Steam	5	4.16.1.4	Hydrometer Test	22
2.6	Explosion and Fire	6	4.16.2	Maintenance-Free Batteries	22
2.7	Chemical	6	4.17	Elektrical Connections	22
2.8	Lifting, Transportation and Residential	6	4.17.1	Wiring	23
2.9	Mechanic	7	4.17.2	Protection	23
2.10	Noise	8	4.17.3	Installation	23
2.11	Electrical	8	4.17.4	Power Factor	23
2.12	Water Exposing / Water	8	4.17.5	Grounding/Grounding Conditions	23
2.13	First Aid in Electric Shock	8	4.17.6	Parallel Operation	24
			4.17.7	Insulation Test	24
3	GENERAL IDENTIFICATION	10	4.18	Sound Absorbers	24
3.1	Generator Specification and Identification	10	4.19	Trailer Type Generators	24
3.2	Diesel Engine	10	4.19.1	Preparation	24
3.3	Alternator	10	4.19.2	Towing	24
3.4	Motor Electrical System	10	4.19.3	Parking Space	24
3.5	Cooling System	10	4.20	Storage 25	
3.6	Chassis and Fuel Tank	10	4.20.1	Storing the Engine	25
3.7	Vibration Isolators	10	4.20.2	Storing the Alternator	25
3.8	Exhaust System	10	4.20.3	Storing the Battery	25
3.9	Control System	11	4.21	Engine Block Water Heater	25
4	LIFTING, PLACEMENT, INSTALLATION AND STORAGE	12	5	DIESEL ENGINE MAINTENANCE	26
4.1	General	12	6	CONTROL SYSTEMS	26
4.2	Genset with Sound Proof Cabin	13	7	STARTING THE GENERATOR	26
4.3	Concrete Base	13	7.1	General Introduction	26
4.4	Transporting, Lifting and Lowing the Generator	14	7.2	Operation Modes	27
4.5	Choosing the Generator Location	15	7.2.1	Automatic Operation	27
4.6	Generator Foundation and Ground	15	7.2.2	Manuel Operation	27
4.7	Basic Functions of Base Concrete	15	7.2.3	Test Operation at Load	27
4.8	Vibration	15	7.3	Protection and Alarms	27
4.9	Ground	15	7.4	Maintenance	28
4.10	Clean Air Suction - Hot Air Shot Sound Cutting Barriers and Roller Shutters	15	7.5	Operating Conditions	28
4.11	Diesel Engine Combustion Air Inlet	16	8	LOCATION AND PLACEMENT OF POWER TRANSFER PANEL (PTP)	28
4.12	Ventilation and Cooling	16	9	ALTERNATOR TROUBLE SHOOTINGS	28
4.13	Exhaust	16	10	DIESEL ENGINE TROUBLE SHOOTINGS	29
4.14	Fuel System	18	11	WARRANTY TERMS AND CUSTOMER'S RESPONSIBILTIES	32
4.14.1	Daily Fuel Tank	18	12	CUSTOMER SERVICE	33
4.14.2	Main Fuel Tank	18	13	MAINTENANCE INSTRUCTION	34
4.14.3	Fuel Line	18			

DEAR DATROFEL GENSET USER;

First of all, thank you for choosing **Datrofel** Generator.

Without taking general safety precautions do not operate, repair and maintenance.

Operation and Maintenance Manual is designed to help you to operate and maintain the Datrofel Generator system correctly.

We recommend that the operator using the generator carefully read this entire manual. Some interventions and maintenance may need to be carried out by specially trained, qualified technical personnel, operators may only carry out tasks up to a certain level.

Operation and Maintenance Manual is designed to help the user easily operate and maintain the generator. It is not a repair book. If the recommendations and rules given in this book are followed, your generator will be able to produce service at maximum performance and efficiency for a long time.

This manual provides general information on the arrangement, operation and maintenance of the generator. You can also find general information and diagrams about the generator you have purchased.

Datrofel Generator; It is designed to be switched on immediately if fuel, coolant, lubricating oil and rechargeable battery / batteries are provided.

Dusty and dirty cleaning ensures regular operation of the generator but with more frequent maintenance.

The parts or details shown in the illustrations and drawings in the manual may differ from the generator set in your hand. These pictures are for informational purposes only.

Maintenance, adjustments and repairs must always be carried out by authorized service personnel and the originalization of trained personnel. Each generator has a model and serial number in the group set mounted on it. (Figure-A) In addition, the production date, voltage, current, power in kVA, frequency, power factor and weight of the manufacturer in this product can be seen.

Datrofel Generator reserves the right to do so in "DIESEL GENERATOR USE AND MAINTENANCE MANUAL".

ACCORDING TO THE REGULATION ON AFTER SALES SERVICES OF INDUSTRIAL GOODS PUBLISHED IN THE OFFICIAL GAZETTE OF 14 JUNE 2003 AND No. 25138;

- Generators identified and announced service life is 10 years.
- Observe the recommended safety and installation precautions.
- Work with Datrofel Generator Authorized Services.
- Use recommended lubricating oil, coolant and fuel.
- Original engine - generator parts must be used.

Datrofel Generator is manufactured according to TS ISO 8528-5 and TS EN 12601 standards.

CE Declaration; ISO 9001: 2015, ISO 14001: 2015, BS OHSAS includes 18001: 2007 certificates.

1.1 GROUP LABEL

Model	Operating Mode
Serial No	Product Date
StandBy kVA	Diesel Engine
Prime kVA	Engine Model
StandBy kW	Engine Serial No
Prime kW	Alternator Serial No
StandBy A	Voltage AC
Prime A	Phase
Cos ϕ	Fuel Tank Capacity
Frequency	Group Weight

Halkapınar Mah. 1348 Sok. 2AE Keremoğlu İş Merkezi Yenışehir - İzmir
Tel: 0232 469 47 00
Faks: 0232 449 47 00

www.datrofel.com.tr Made in Turkey

İzmir Office: Halkapınar Mah. 1348 Sok. 2AE
Keremoğlu İş Merkezi Yenışehir – İzmir

Tel : 0232 469 47 00

Faks : 0232 449 47 00

e-mail : info@datrofel.com.tr



Figure-A / Datrofel Generator Label

This labeling information is required for ordering spare parts, processing the warranty or providing service.

2.1 GENERAL

Your generator is designed and manufactured to operate safely. However, the user is responsible for the security. The risk of accident is very low if the specified safety precautions are applied. It is the user's responsibility to ensure the necessary safety before performing any technical operation or operation. The generator must only be operated by authorized and trained persons.

WARNINGS



- Read and understand all safety precautions and warnings.
- Read all warnings in the manual book carefully and make sure that you do not interfere with the generator.
- Instructions and safety precautions in this book are not followed in case of accidents and possible accidents.
- Never operate the generator in a unsafe manner.
- If there is an unsafe condition, place the hazard warning sign, cut off the emergency stop function and the negative (-) pole of the battery until the negative condition is corrected operation.
- It is not trying not to be authorized to the generator group. Assembly of warning signs in the assembly area.
- Before performing maintenance, repair or cleaning of the generator, cut off the emergency stop method and the negative (-) terminal of the battery.
- The number of authorized service personnel performs installation and operation in accordance with their standards. Maintenance and repair processes should only be carried out by authorized services.
- Find out the location of the Emergency Stop Button. The Emergency Stop Button must only be used in an emergency.



2.2 PROTECTIVE MATERIAL USAGE

- Use appropriate protective materials before using the generator.
- Use clothing that will not be attached to the rotating parts of the generator.
- Use headphones to prevent hearing problems caused by generator noise.
- Wear safety goggles to prevent possible eye injuries.
- Use all chemicals and solutions with protective gloves in accordance with the instructions for use.



2.3 FIRE EXTINGUISHERS

- Have BC and ABC type fire extinguishers ready for use with the generator.
- How to use fire extinguishers to relevant personnel(s) it is explained.
- The fire extinguisher should be checked regularly by the competent authority and competent persons.

- The generator room should not be used for storage.
- Do not fill the fuel tank with the engine running.
- Do not allow smoking, sparks, arc devices or other sources of ignition to operate or operate near the fuel tank or generator set.
- Adequate safety precautions must be taken to avoid leaks in the fuel lines. Engine fuel connections must be made with flexible lines (fuel hose). Do not use copper pipes.



2.4 PRECAUTIONS AGAINST LEAKAGE

During maintenance or repair work, care must be taken to ensure that liquids in the diesel engine do not leak into the environment. Before opening the liquid-containing parts precautions should be taken.



Improper disposal of waste is a threat to the environment can. All waste chemical fluids must be disposed of in accordance with environmental regulations. Sealed containers should always be used when disposing of liquids. Never spill waste chemical fluids on the ground, drains or water supplies.

2.5 PRESSURED WATER STEAM

- Always wear safety glasses when cleaning the cooling system. Maximum (30 psi) water pressure can be applied for cleaning.
- Compressed air and water can cause dirt and hot water to come out, resulting in injury.
- Wear protective equipment, shoes and goggles when using compressed air. Wear safety goggles or face shield.
- Do not open the radiator filler cap until the coolant has cooled. Before opening the radiator cap fully, loosen the cap slowly to reduce the high vapor pressure.
- Do not operate the block water heater when there is no water in the radiator.
- The cooling water boils at a higher temperature than water under pressure.
- Do not open the cover of the radiator while the engine is running.
- After the diesel engine has cooled down, open the radiator cap in a controlled manner.



2.6 EXPLOSION AND FIRE

- Flammable materials must not accumulate in the area where your generator is located.
- Fuel and oil must be stored in sealed containers and away from unauthorized persons.
- Engine oil and some cooling mixtures are flammable. Flammable liquids spilled on hot surfaces and electrical parts can cause fire.
- Fire and property damage may result.
- Proper ventilation in the generator room conditions.
- Observe the risk of diesel engine in an environment where flammable gases may enter the air intake system. These gases can cause the engine to rise to high speed. Injuries and engine damage may result.
- Flammable materials must be kept in protective containers. Do not smoke in areas with flammable materials.
- The electrical cables must be properly and securely connected. If there are loose or frayed cables, please contact an authorized service center before starting the engine.
- Sparks can cause a fire. If safe connections, correct cables and properly maintained battery cables are used, no arc will occur.
- Do not allow incidents such as flame, sparks, or smoking that may cause a fire around the fuel.
- An emergency exit door should be provided for easy exit of personnel in case of any fire.
- Never place a metal object between the (+) and (-) terminals when checking the battery charge. Use a voltmeter or hydrometer.
- Before connecting or disconnecting the battery, disconnect the charger.
- Batteries should be kept clean. When using the generator set, use the recommended cable, connection and battery covers.
- Do not start the generator if there is a fuel leak.
- Do not refuel while the diesel engine is running.
- Do not use aerosols for initial start-up. Doing so may cause explosions and injuries.
- Do not charge frozen batteries, as this may cause explosion.
- Keep the generator room floor and generator set clean. In case of spills of fuel, oil, battery electrolyte or coolant, these must be removed immediately.



2.7 CHEMICAL

Lubricating oils, fuels, coolants and battery electrolytes used are of industrial type. If they are not used properly, they may harm your health and / or environment.

WARNINGS



- Do not allow lubricating oil, fuel, coolant and battery electrolyte to come in contact with the skin. In case of accidental eye contact with the battery electrolyte, seek immediate medical attention. In case of skin

- contact, wash the contact area with soapy water.
- Do not wear clothing contaminated with fuel or oil. When preparing the battery, wear an acid resistant apron, face mask and safety goggles. If battery electrolyte is spilled onto the skin or clothing, immediately clean the spilled area with plenty of pressurized water. Wash with soap and water.
- Hot oil can cause injury. Avoid contact with skin. Hot parts must not be touched with the skin.
- The diesel engine is hot and the coolant is hot. At the same time, the cooling water is under pressure. Radiator and hoses have hot coolant. Contact with hot coolant and steam will cause burns.
- Allow the cooling system components to cool before draining the cooling system.
- Electrolyte is a kind of acid. This may cause injury. The electrolyte must not come into contact with the skin and eyes. Wear protective gloves and goggles during maintenance of batteries.
- Always wash your hands with soap and water after touching the batteries.



2.8 LIFTING, TRANSPORTATION AND RESIDENTIAL

This section covers the installation, lifting and storage of the generator. Read this section before moving, lifting, placing or towing the generator. Observe the following safety precautions.

WARNINGS



- Fuel storage systems; ensure that it is installed in accordance with the relevant standards.
- Make electrical connections in accordance with the relevant standards. Install external grounding and make connections.
- For electrical connections, ensure that the connections are made at the correct torque.
- Exhaust gases are hazardous to your health. Exhaust gases of all generators located in closed spaces to the atmosphere must be ensured to be discharged to the outside by sealing black pipes in accordance with the relevant standards. Precautions must be taken against the contact of the hot exhaust muffler and combustible material to the exhaust pipes and contact of personnel. Evacuate the exhaust gas to the open area without danger.
- Place your generator in an area where ventilation conditions are appropriate.
- Do not lift the generator using the alternator and engine lifting eyes. Use the lifting points on the chassis to lift the generator. For cabin generators, use the lifting points on the top of the cabinet or the lifting points on the chassis. Pay attention to the warning labels.
- Make sure that lifting equipment and support structures are stable and capable of carrying the generator. When the generator is lifted, all personnel must be kept away from the generator.
- Do not use chain-slings with a segmented-attachment. Do not lift with a lifting angle exceeding 60°.
- NEVER exceed the lifting capacity.

- When not in use, hang the lifting and mooring chains on the appropriate hooks and prevent them from rusting prevent crushing and the effects of corrosive substances.
- Do not use chain slings in corners without protective material.
- NEVER stand under the load raised by the chain sling.
- Worn, bent, rusted, elongated or damaged in any way NEVER use chain straps that are not.
- NEVER tie knots to the chain, do not weld.
- Check that the crane hook moves freely in the main coupling ring.
- Always avoid moving loads.
- Shorten and use chain slings with shortening hooks, not knotting.
- Make sure the center of gravity of the load is absolutely in the middle of the sling.
- When using multiple link chains, ensure that all levers have the same inclined angle.
- Do not lift loads with twisted chains.
- When lifting sharp-edged loads, protect the chains with the appropriate bumpers.
- Place the load on the full bearing, not on the end of the hook.
- Make sure that the main ring moves freely on the crane hook to which it is attached.
- Do not use the chain when you detect damaged parts and replace it with a new one.
- Do not overload the chain sling, observe the lifting angle and if you are unsure, choose an upper chain diameter.
- Check chain slings in case of breakage and cracks.
- Replace the chain if the wall thickness decreases, exceeds 10% of the nominal diameter.
- When a chain is bent or twisted, replace it completely.
- Replace if you detect sloped links, cracked or notched chains.
- NEVER use when chains are longer than 5% in length.
- Chains used to lift loads must not have knots or twists. Feed the corners and the chains with the appropriate cushions when lifting rigid and cutting angular loads. NEVER fasten a broken lifting or mooring chain with wire or fasten it with bolts.
- When using multiple-arm slings, connect the heads of the sling arms to the same ring and make sure that the sling arms have the proper clearance.
- Replace the sling when the elongation at each control point exceeds 5%.
- Fasten Cloth / Polyester Straps to carry load at full width.
- If more than one Cloth / Polyester slingshot is used instead of a sling for lifting the load, make sure that the raw materials are the same. NEVER lift loads with different special slings.
- Observe the horizontal angle of the sling during lifting. NEVER forget that the larger the angle, the lower the sling lift capacity will be.
- If there are uneven angles in lifting with two slings, lift that load as if it were to be lifted with a sling.
- Do not use or store Cloth / Polyester slings in the presence of acids or vapors or other corrosive chemicals.
- Cloth / Polyester slings, dry when wet, wash when dirty and store dry.
- Determine the weight and center of gravity of the load to be lifted.
- When lifting the load with a sling, do not allow anyone to be in the surrounding area.
- Errors and damages that adversely affect the long-term and safe use of slings; never use slings when surface wear, longitudinal and cross cuts,

abrasion points, mesh loops or knots.

- If more than one sling is used during lifting, check that the sling lifts evenly.
- Avoid sudden swinging and shaking.
- NEVER slide the load onto the sling you are lifting.
- NEVER hold the load for a long time with the sling you will be lifting.
- Do not store damaged slings. Store slings in clean, dry, well-ventilated areas.
- Allow the slings to vent. Sunlight (ultraviolet exposure to radiation).
- Keep slings away from high temperature areas.
- Store in areas where there is no risk of pinching or crushing.
- Make sure that the webbing or sutures of the sling are not damaged.
- NEVER use a knotted, twisted, or repaired sling.
- Do not match the seams of the slings to the hook area or other lifting gear.
- Ropes during use; Do not rub, drift on the ground, step on ropes or drive over sharp or rough surfaces.
- Observe all traffic regulations, standards and other regulations when towing the trailer generator. This includes the necessary equipment and speed limits that are expressly specified in the regulations..
- Do not allow personnel to travel on a mobile generator. Do not allow personnel to stand on the towbar or between the mobile generator and the towing vehicle.
- Do not install and operate the generator in an environment classified as hazardous unless specifically designed.

2.9 MECHANICAL

Your generator is designed with enclosures to protect it from moving parts. However, precautions must be taken to protect personnel and devices from other mechanical hazards when operating in the generator room.

WARNINGS



- Always use the diesel engine in a well-ventilated area. If the diesel engine is in a confined space, take the exhaust system out. The diesel engine exhaust gas contains hazardous waste.
- As long as the diesel engine is running, the crankcase discharges hazardous waste from the ventilation line. Ideal ventilation in the generator room conditions should be provided, the crankcase ventilation line should be evacuated out of the room.
- Your generator is designed with enclosures to prevent injury from moving parts. Nevertheless, care must be taken to protect personnel and equipment from other mechanical hazards when working around the generator set.
- Do not operate the generator set with the housings removed. Do not attempt to reach under or around the enclosures for any reason while the generator is running.
- Keep long hair, loose clothing and jewelry away from pulleys, belts and other moving-rotating parts.
- Sharp edges, sharp corners, hot oil, hot fuel, hot coolant, hot exhaust wiring and avoid contact with hot surfaces due to the risk of injury.



2 / SAFETY

- Some moving parts may not be clearly visible when the generator is running.
- Protect your jewelry, clothing and hands from moving part by keeping them far away.

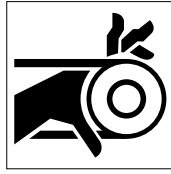

- Keep electrical equipment clean and dry. Replace electrical equipment where insulation is worn, cracked or broken. Replace worn, rusted and discolored terminals. Keep the terminals clean and make connections with the proper tightness.
- Isolate all connections and unused cables.



2.10 NOISE

(The sound levels of the generators with sound isolation cabinets are defined in CE DECLARATION OF CONFORMITY and ISTITUTO GIORDANO certificates. Sound levels are between 93 - 95 dB (A) and comply with the directive 2000/14 / EC. During operation and maintenance, the headphones must be used in accordance with the noise-canceling safety rules. It is dangerous. The noise level label is identified on the side.



The sound levels of open type generators (without sound insulation cabin) are above 70 dB (A). During operation and maintenance, the headphones must be used in accordance with the noise-canceling safety rules. It is dangerous.



(A-weighted sound pressure value in the environment where the generator is running is above 70 dB (A). The value is determined according to EN ISO 4857: 2009 standard as indicated in the double-altitude as indicated on the label.)

WARNINGS



- Wear headphones while operating in the generator room.

2.11 ELECTRICAL

Efficient and safe operation of electrical devices ensures that the installation, use and maintenance.

WARNINGS



- The load line connection of the genset must be carried out by an authorized service person who is trained, authorized and competent in accordance with the relevant electrical codes and standards.
- Before starting or disconnecting the load from the genset, stop the genset operation and disconnect the battery negative (-) terminal.
- Do not make or disconnect the load when it is standing on a puddle.
- Before starting the generator (including mobile generators) make sure that the generator is grounded.
- Do not touch the conductors, connection cables and electrical parts on the generator with any part of your body or any uninsulated object.
- After the load connection has been made or after the load connection has been removed, replace the cover of the connection area. Never switch on the generator unless the cover is securely in place.
- You must connect your generator to loads and electrical systems that match its power and electrical characteristics.

2.12 WATER EXPOSING / WATER

WARNINGS



- Water or moisture that will come into contact with the electric current, especially the generator panel and alternator, will cause the electric arc. This will result in damage to the generator and injury to personnel resulting in death.
- Do not operate the generator in the presence of excessive moisture or water. Inform the authorized service. However, the authorized service can take the necessary precautions and start the generator after removing the water and moisture from the environment.

2:13 FIRST AID WARNINGS IN ELECTRIC SHOCK

WARNINGS



- Do not touch the exposed person with his bare hands before turning off the power supply.
- Free the victim from electric current.
- If this is not possible, stand on dry insulating material and, preferably, use an insulating material, such as dry board, to remove the exposed person from the conductor.
- If the survivor is breathing, move the survivor to the recovery position as described below.
- If the person who has been exposed to electricity has lost consciousness, use the following procedure to resuscitate.

OPENING THE RESPIRATORY PATH

1. Tilt the victim's head backwards and raise his chin.
2. Remove objects such as denture, gum that may have escaped into the mouth or throat of the victim.



RESPIRATORY

Check whether the victim is breathing by listening, listening and feeling.

BLOOD CIRCULATION

Check the victim's neck pulse.

IF YOU CAN'T BREATHE BUT IF YOU HAVE A PULSE

1. Firmly close the victim's nose.
2. Take deep breaths and join your lips with the victim's lips.
3. Blow slowly through the mouth, observing the rise of the rib cage. Then stop blowing and allow the chest to fully descend. Average to casualty per minute breathe out 10 times.
4. If the victim is to be left alone to call for help, return briefly by breathing 10 times and continue breathing.
5. Check the pulse every 10 breaths.
6. Move the victim to the recovery position as soon as he starts breathing.

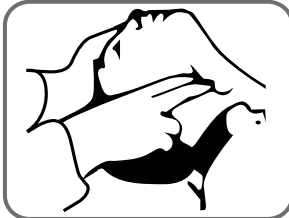

IF YOU CAN'T BREATHE AND NO PULSE

1. Seek medical attention or call the nearest health facility. Breathe the victim twice and start cardiac massage as follows.
2. Place the palm of your hand 2 fingers up from the junction of the rib cage.
3. With your other hand at your fingers lock.



4. Holding your arms upright, press down 4-5 cm at 15 times per minute.
5. Repeat 2 exhale and 15 cardiac massage until medical attention is received.
6. If the victim's condition improves, continue breathing by checking his pulse. Check the pulse every 10 breaths.
7. As soon as breathing begins, bring the victim to the recovery position.



HEALING POSITION

1. Tilt the victim to the side.
2. Keep the head tilted with the chin facing forward to ensure that the airway is open.
3. Make sure the victim does not roll forward or backward.
4. Check the breathing and pulse regularly. If either stops, repeat the above steps.

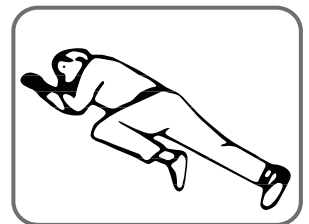
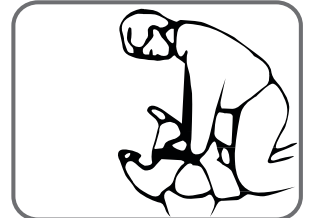

WARNING

- Do not give liquids such as water until the victim is conscious again.

3 / GENERAL DESCRIPTION

3.1 GENERATOR SPECIFICATION AND IDENTIFICATION

Datrolfel Generator is of high quality and designed as a whole. Figure B shows the main parts of a typical generator. However, each generator may vary depending on the configuration and size of its main components. For this reason, parts of the generator set are generally described in this section. More information is provided later in this book. Each generator has a set of labels for that generator (Figure-A). This label contains information that identifies the generator and the operating characteristics of the generator. This is the model number, serial number, alternator voltage and frequency, output power in kVA, weight and year of manufacture. The model and serial number identify that generator only, and will be required if warranty operation, service and spare parts are required.

3.2 DIESEL ENGINE

Diesel engine that drives the alternator has been chosen because of made especially for gensets and its reliability. The engine is a 4-stroke industrial heavy-duty type and is available on all accessories to provide reliable energy. Replaceable dry type air filter, low oil pressure sensor, low water level sensor, high temperature sensor, mechanical or electronic engine speed control governor are some of these accessories.

3.3 ALTERNATOR

The output voltage and power of the genset are produced by a self-excited, self-regulating, brushless alternator with cage protection in IP 21-23 protection standard (particle and drip protection). The terminal box made of steel sheet is mounted on the alternator.

3.4 MOTOR ELECTRICAL SYSTEM

The engine electrical system is a negative earthed 24 or 12 V D.C. This system consists of electric starter, battery and battery charging alternator. One for 12 V electrical system and two maintenance free or low maintenance type batteries for 24 V electrical system. Other types of batteries can be used as an option.

- All interventions described in this section should be performed by authorized and competent persons.

3.5 COOLING SYSTEM

The engine cooling system must be air-cooled or water-cooled. An air-cooled system includes a high fan that delivers cool air into the engine to cool the engine. Water cooled system consists of radiator, fan, circulation pump and thermostat. The alternator has an internal cooling fan and ventilation housings to cool the alternator windings.

- Adjust the degree of freezing of the coolant, which is an antifreeze-water mixture, in accordance with the weather conditions in your area.
- Dispose coolant discharged from the cooling water of in accordance with the Environmental regulation .

3.6 CHASSIS AND FUEL TANK

The motor and the alternator are mounted on a steel frame. There is a fuel tank in the chassis. Separate fuel tank can be supplied in large power generators or upon customer request.

- Check that the fuel drain valve is closed before the first fuel filling.
- Before the first refueling, check that the blind plugs on the fuel tank are fitted and tight.
- Keep the absorbent pads and barriers at the operating site ready to prevent possible leakage or spillage during refueling.
- When refueling, stop filling before the tank is completely filled. Otherwise, there will be fuel overflow from the installation intervals of the equipment on the fuel tank or the winding pipe.
- For generators with external fuel filling feature, check the condition of the pipe between the filling port and the fuel tank, such as blockage or folding, and start the fuel supply at a suitable flow rate. Otherwise, the fuel will return and cause the vehicle to form.

3.7 VIBRATION ISOLATORS

Vibration isolators are used to reduce the vibration of the generator while it is running and to prevent the generator from transmitting vibration to the floor where it is placed. These isolators are located between the engine and alternator foot and the chassis. Special vacuum type isolators are provided between the chassis and ground with the generator.

- It is necessary to install the generator at the moment of lowering during the sailing to the installation area. Rubber wedges are shipped on the generator chassis.
- Do not get under the connected load during the installation of rubber blocks. Take care by wedging under the chassis.

3.8 EXHAUST SYSTEM

In cabin generators, the exhaust silencer is mounted on the exhaust outlet together with the piping. Exhaust silencer is provided separately in some models of cabin and non-cabin generators. The generator must be installed in such a way as to prevent gas leakage before commissioning. The muffler and exhaust system reduce noise from the engine and direct the exhaust gas for safe exit.

- Do not connect the exhaust system of two or more engines together.
- Exhaust the engine through brick tile or concrete block chimney or similar structures..
- The exhaust manifold must be enclosed.
- Do not use the exhaust gases for space heating.
- Insulate the exhaust pipes that are exposed to personnel or close to flammable material against heat.
- Suspend the exhaust system from the ceiling. Especially in turbocharged engines, there should be no forced loading and torsion on the exhaust manifold.
- Exhaust installation at the point of exit to the atmosphere in rainy weather it is of great importance that water does not enter the exhaust system. Otherwise, the diesel engine will be severely damaged.
- Periodically ensure that the exhaust gases do not leak into the installation area.
- Necessary measures have been taken in order to prevent water and / or foreign matter from entering the exhaust line at the exhaust outlet on the generator in the generator groups shipped with the silencer system de-mounted. The same silencers that are de-mounted at the time you intervene at the time of installation.

3 / GENERAL DESCRIPTION

3.9 CONTROL SYSTEM

Manual or automatic control system and panel are placed on the generator in order to protect the generator from possible faults and control the output and operation of the generator.

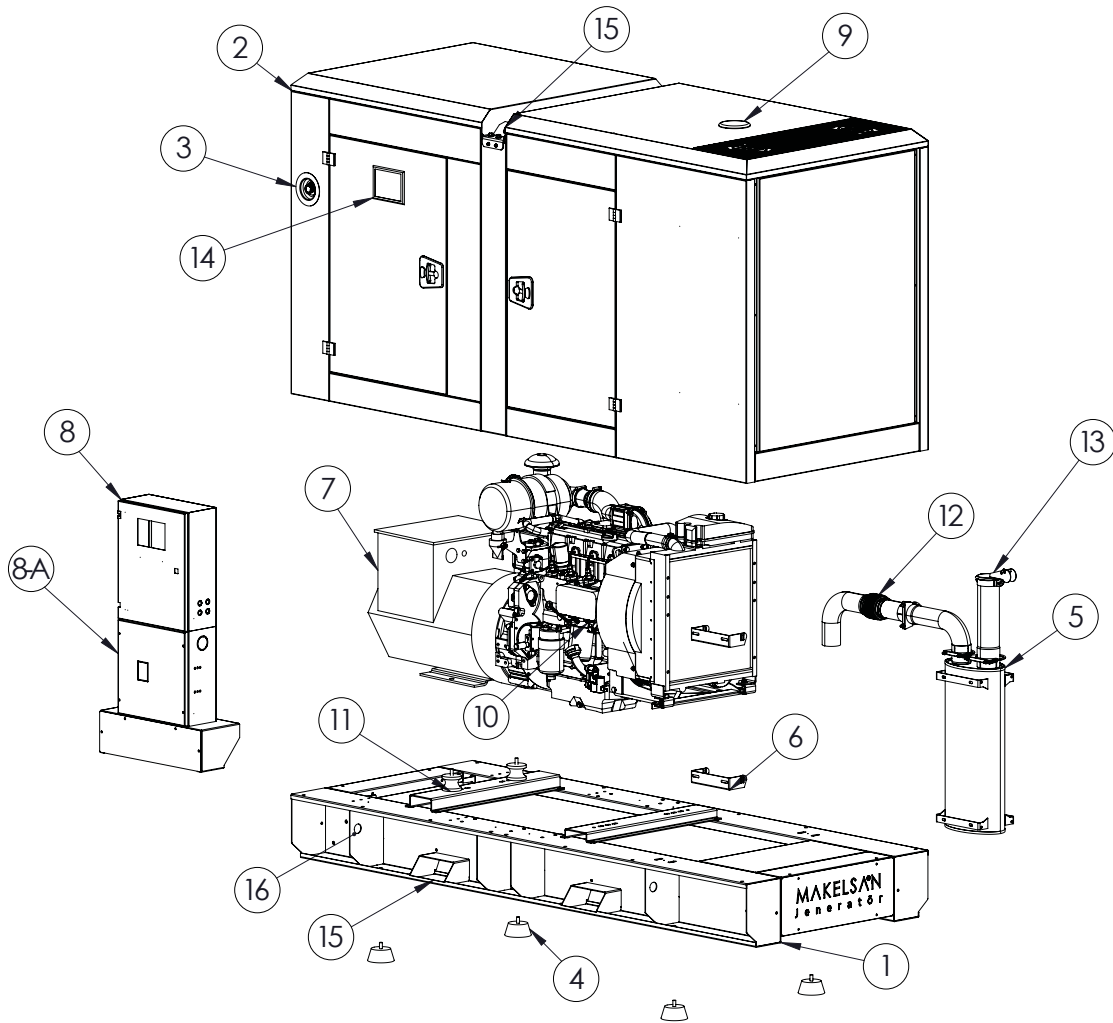

Figure-B / Typical Genset

- | | |
|---|---|
| 1. Steel Chassis | 9. Coolant Filler Cap |
| 2. Cabinet | 10. Diesel Engine |
| 3. Emergency Stop Button | 11. "U" Type Vibration Wedge |
| 4. Vacuum Type Vibration Wedge | 12. Compensator |
| 5. Muffler / Exhaust | 13. Eegous Outlet Cap |
| 6. Muffler Strap | 14. Control Panel Viewing Window |
| 7. Alternator | 15. Overhead Lifting / Forklift Loading Point |
| 8. Control / Control Panel | 16. Lifting Point from Chassis |
| 8A. Load Output Terminal / Load Output Switch | |

4 / LIFTING, PLACEMENT, INSTALLATION AND STORAGE

4.1 GENERAL

In order to make the layout of the generator, the dimensions of the generator must be known. Once you have this information, the plan can be prepared. This section contains the necessary and important factors for the efficient and safe placement of the generator.

When selecting an installation site for the generator, the following factors must be selected and the necessary applications made.

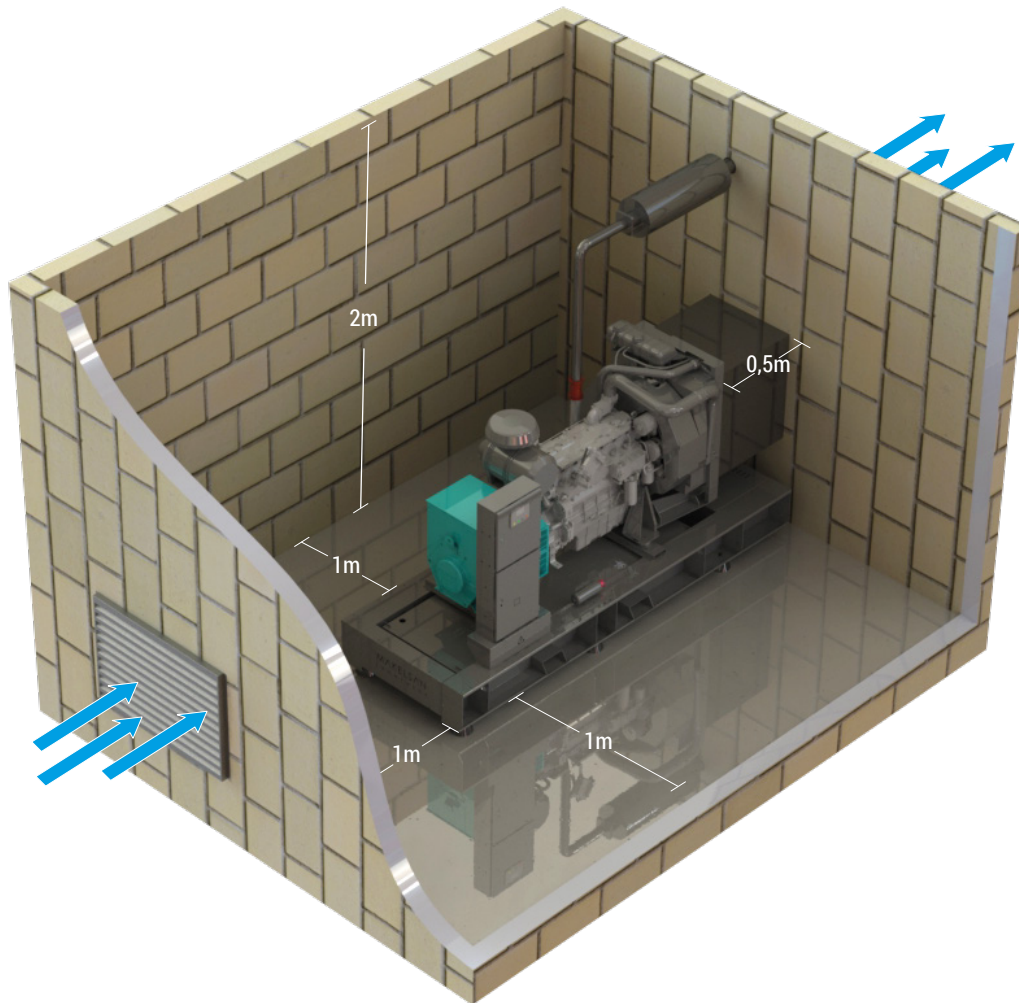

Figure-C

- Adequate clean air suction,
- Adequate hot air firing,
- Suitable exhaust gas throw,
- Constructing the concrete base on the scale or determining the concrete area in the scale,
- Protection from adverse weather conditions, (sun, type rain and snow, etc.),
- Protection from adverse environmental conditions, (excessive dust, moisture, moisture, etc.)
- In order to provide service, minimum 1 m. Leaving a wide width,
- Designing the entry door width based on the possibility of removing the generator from possible installation area.

WARNING

- The installation area should be selected in such a way that it does not cause work accidents due to slipping and falling, such as floor covering, oil leakage.

4 / LIFTING, PLACEMENT, INSTALLATION AND STORAGE

4.2 GENSET WITH SOUND PROOF CABIN

A generator set with a cabinet must be placed on a level floor. Otherwise, the cabinet doors will not open and close easily. Cabinet generator sets should be installed in open area. If the cabin generator set is installed in the room, cooling with sufficient fresh air must be ensured. The produced hot air and exhaust gas should be discharged to the open area with the help of duct-installation. The hot air duct system and the exhaust system must be designed and implemented in conditions that do not affect the performance of the generator set.

When the generator is placed in a cabinet, transport and placement will be greatly simplified and minimal installation costs will occur. Generator with cabin protects against unauthorized use and external factors. Choosing the generator with cabin will provide an advantage in terms of noise and the elimination of negative environmental factors.

4.3 CONCRETE BASE

The concrete base shall be designed to withstand the weight of the generator set. The height should be 200-300mm. No more than 250mm area should be left around the generator. Consult a specialist for more details.

The generator installation floor must be able to withstand the static weight and any dynamic loads caused by engine operation. If there is a possibility of occasional puddling in the selected floor area, the height of the concrete base should be increased according to the size of the risk.

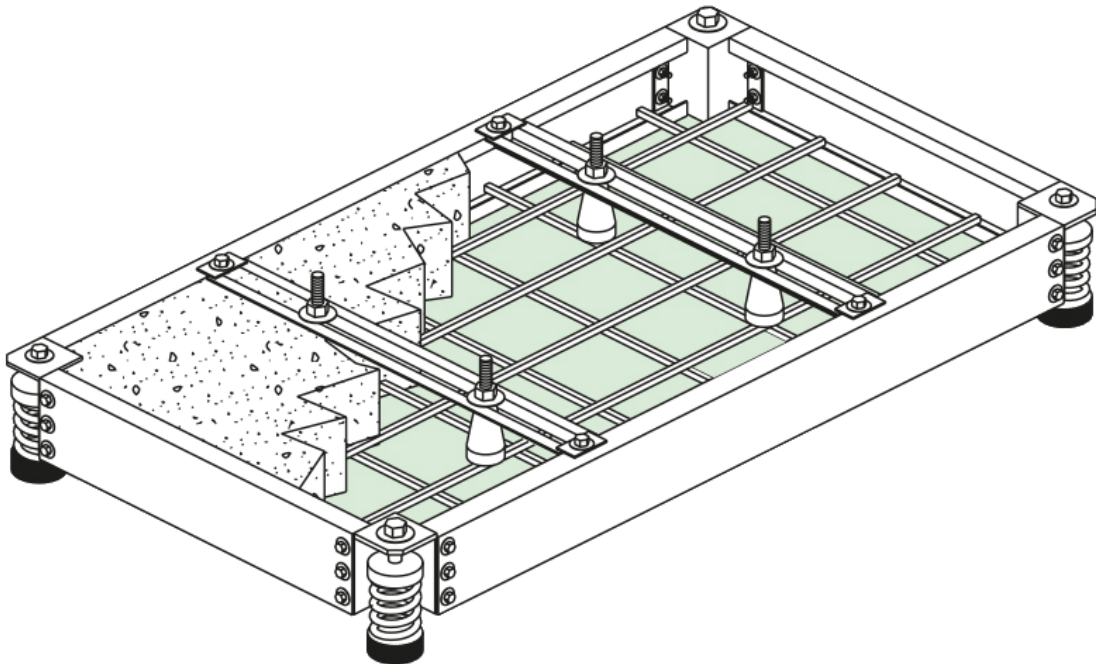

4 / LIFTING, PLACEMENT, INSTALLATION AND STORAGE

4.4 TRANSPORTING, LIFTING AND LOWING THE GENERATOR

Incorrect lifting of the generator can cause serious damage to parts. The generator frame has been specially designed to facilitate the transport of the generator.

The generator can be lifted using specially designed forklift lift points on the chassis. (See Figure-E) When transporting with a trans pallet, it will be appropriate to nail wood beams for safety purposes under the chassis in order to prevent damage to the chassis.

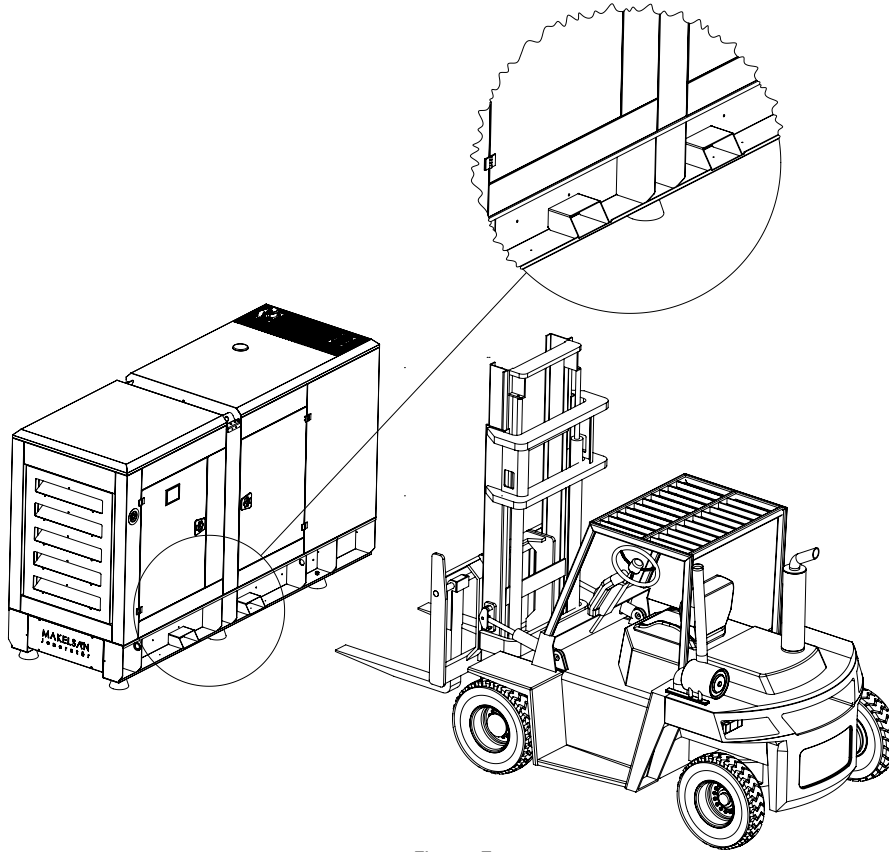

Figure-E

Use the lifting points designed on the chassis to lift and lower the generator set.
Use suitable size "U" bolt shackle and suitable capacity webbing sling. (See Figure-F)

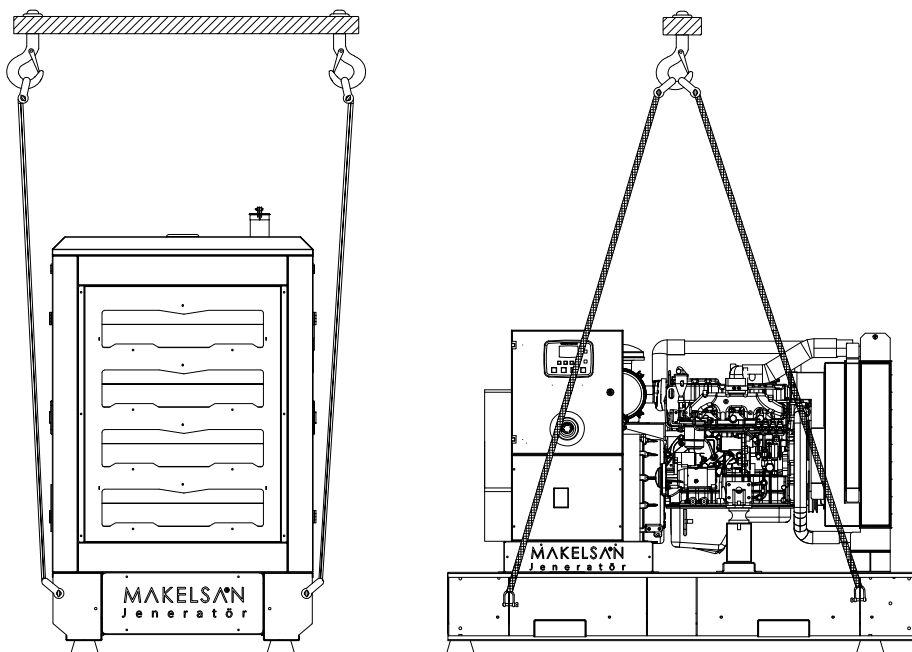

Figure-F / Lifting the generator by crane

4 / LIFTING, PLACEMENT, INSTALLATION AND STORAGE

To avoid damaging the set when lifting from the chassis, a distributor lift joint is required. This rod should be placed above the center of gravity for vertical lifting.

WARNINGS



- When lifting and lowering the generator, use suitable lifting equipment.
- When the generator is lifted for transportation, keep people in the vicinity away from the generator because of the risk of life.
- Do not lift the generator using the engine or alternator lifting eyes.
- Use the lifting points on the chassis or cab when lifting the generator with or without cab by crane.
- Steel sling to be used to lift the generator, cloth sling or the parts where the chain contacts the generator set.
- Guide ropes should be used to prevent the generator from being lifted off the ground.
- Lower the generator set to a floor level on a balance capable of supporting its weight.
- Check the joints for cracked welds or loose nuts and bolts before lifting.
- Do not lift and lower the generator in severe wind conditions.
- Do not attach a sling or hook directly to the top lifting slots on the cab. Make the connection with eyebolts. Otherwise, it is possible that the lifting slots will tear and cause the generator to fall, causing accidents that may cause material, injury or even loss of life.

4.5 CHOOSING THE GENERATOR LOCATION

The following conditions should be considered when choosing a location.

- The room floor of the generator should be smooth and capable of supporting the total weight of the generator.
- It must be protected against rain, snow, flood water, direct sunlight, freezing cold and extreme temperatures.
- There must be adequate ventilation.
- There must be at least 1 meter of space around the generator and at least 2 meters of space on the generator for cooling, servicing and maintenance of the generator.
- It must be protected against airborne harmful substances such as dust, thread, smoke, oil fumes, steam and engine exhaust fumes that are corrosive or conductive.
- Protects against falling objects such as trees or poles must be protected.
- In order to carry the generator into the room, there must be a suitable path for the generator to pass.
- In order to allow the generator to enter and exit the room as a whole, the room door should be constructed in case the generator enters into the room or possible repair or relocation operations.
- Restrict unauthorized access to the generator space.
- If it is necessary to place the generator outside the building, the generator should be placed in a cabin or a room. It is also useful to use a cabinet to temporarily operate the generator inside or outside the building.
- Place the earthing plate or rod in the location closest to the generator.

4.6 GENERATOR FOUNDATION AND GROUND

A smooth concrete floor is sufficient to carry the entire weight of the generator (including oil, antifreeze, and fuel). Special base concrete

is recommended. The design of the base concrete (including seismic identification) of this type of work should be the responsibility of the civil engineer. (See 4.3)

4.7 BASIC FUNCTIONS OF BASE CONCRETE

- Carrying the total weight of the generator.
- Ensure that the generator is on a floor and that proper lubrication conditions are generated.
- To protect the generator from possible flooding.
- The vibration generated by the generator group from the whole structure isolate.

4.8 VIBRATION

Your generator set is equipped with rubber vibration mounts to minimize vibration transmitted to the floor when the generator is running.

The rubber wedges are in the form of a group between the engine / alternator foot and the chassis, and another group between the chassis and the ground.

Flexible connections must be made at the connection points of the generator set such as air duct, exhaust system, fuel system. In this way, damages due to vibration will be minimized during the first operation, operation and stopping processes.

4.9 GROUND

The generator may be placed on the concrete floor. However, in permanent installation, the use of raised concrete in the area where the generator frame will be stepped will provide different benefits. (See 4.7.2)

Uneven and weak concrete base can cause unwanted vibration.

The floor should be sloping, on the balance and free of puddles. At the same time, it is necessary to cover the floor with a structure that will cause minimum leakage and injury to persons with possible oil leakage.

4.10 CLEAN AIR SUCTION - HOT AIR SHOT SOUND CUTTING BARRIERS AND ROLLER SHUTTERS

Clean Air Suction - Hot Air noise cut barriers must be installed on the wall according to the technique. Louvers installed in front of the barrier should provide low resistance at the air inlet. For this, minimum 50% air passage area should be provided. With sound barriers, the sound level should be 85 dBA at a distance of 1m. It will be necessary to increase the thickness of the sound barriers to reduce further noise. Wireframe should be used to ensure the lowest counter resistance to prevent birds and small creatures from entering the interior of the louvers. "Z" type material should never be used in hot air shot louvers.

4 / LIFTING, PLACEMENT, INSTALLATION AND STORAGE

4.11 DIESEL ENGINE COMBUSTION AIR INLET

Diesel engine combustion air should be as clean and cool as possible. Combustion air is drawn from the environment of the generator by means of an air filter mounted on the engine. Occasionally, the surrounding air may not be suitable due to dust, dirt and temperature. In these cases an air intake duct can be installed. This channel is motor It provides fresh air to the air filter from outside or from another room by force or with a fan motor drive. If the fan motor drive method is applied, a fan motor of the appropriate capacity must be installed.

4.12 VENTILATION AND COOLING

The engine and alternator emit heat, causing the ambient temperature to rise. Increasing the temperature negatively affects the efficiency of the generator. It is therefore sufficient to keep the engine and alternator cool ventilation should be provided. The air flow should be as shown in (Figure-G). The air must be entered by the alternator in sequence, and it must be evacuated from the room by means of a flexible tarpaulin of the bellows type from the tent cloth by going through the diesel engine and passing through the radiator.

If a duct is not used to discharge the hot air out of the room, the hot air will be short-circuited to the generator room and the desired cooling efficiency will not be achieved.

Sharp corners should be avoided in the radiator hot air duct or chimney (Figure-H). A guiding arrangement should be made to rotate the exhaust air (Figure-G).

The air inlet and outlet windows must be large enough for fresh air to be sucked in and easy to escape from the room. With an overall calculation, the air inlet and outlet windows should be at least 50% larger than the radiator area. Negative weather conditions of the generator input and output windows should have blinds to prevent These louvers may be fixed but should be movable for cold climates. Shutters can be closed when the generator is not started. The warm air thus remains in the room, making it easier to start and load. In a generator room with automatic control system, if the louvers are moving, they can be moved automatically. In this way, the engine, the shutters can be opened immediately upon starting and the shutters can be closed by stopping the engine.

4.13 EXHAUST

The purpose of the exhaust system is to reduce exhaust noise and to direct the exhaust fumes to the appropriate area so as not to cause danger or discomfort. A suitable exhaust silencer must be fitted to the exhaust pipe to reduce engine noise.

WARNINGS



- Keep the hot exhaust silencer and exhaust pipe away from flammable materials and keep them safe for personnel protection.
- Inhalation of engine exhaust gas is dangerous. The gases of all generators in enclosed spaces must be disposed outside the room with sealed pipes in accordance with the standards.

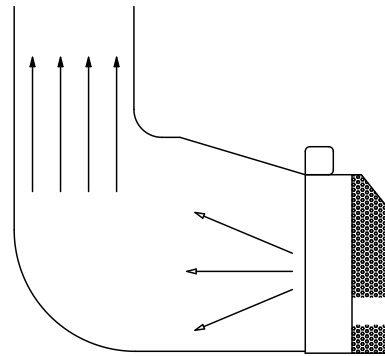

Figure-G / Ventilation of hot air discharged from the radiator by air ducts

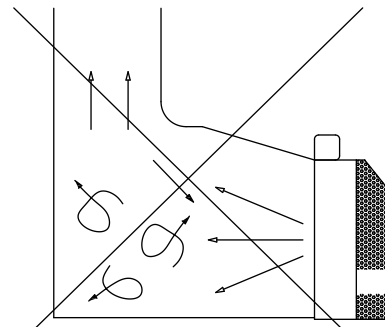

Figure-H / Weak hot air shot ventilation system

- When designing the exhaust system, it should be ensured that the back pressure does not exceed the back pressure value allowed by the engine manufacturer. Excessive back pressure will cause engine damage. To reduce back pressure, the exhaust pipes should be as short and straight as possible. Each bend required must have a curvature of at least 1.5 times the inner diameter of the pipe. The use of pipes larger than 1 inch of pipe diameter at every 4 meters or 2 bends would be appropriate to reduce exhaust back pressure.
- A flexible compensator or derivative interconnection must be installed between the exhaust manifold / turbo outlet and the exhaust pipe system to prevent engine vibration from being transmitted to the exhaust pipe system and to the building due to expansion.
- The weight of the exhaust system to be prepared must be supported by the surrounding structures (especially the ceiling) to avoid weighting the engine manifold and turbocharger outlet. The weight of the exhaust system must be given to the building. Tensioning elements or seismic connection elements can be used for this purpose.
- Parts of the exhaust system installed in the generator room must be insulated to reduce noise levels and radiated heat. The muffler and exhaust pipes should be located away from flammable materials due to possible fire risk.



4 / LIFTING, PLACEMENT, INSTALLATION AND STORAGE

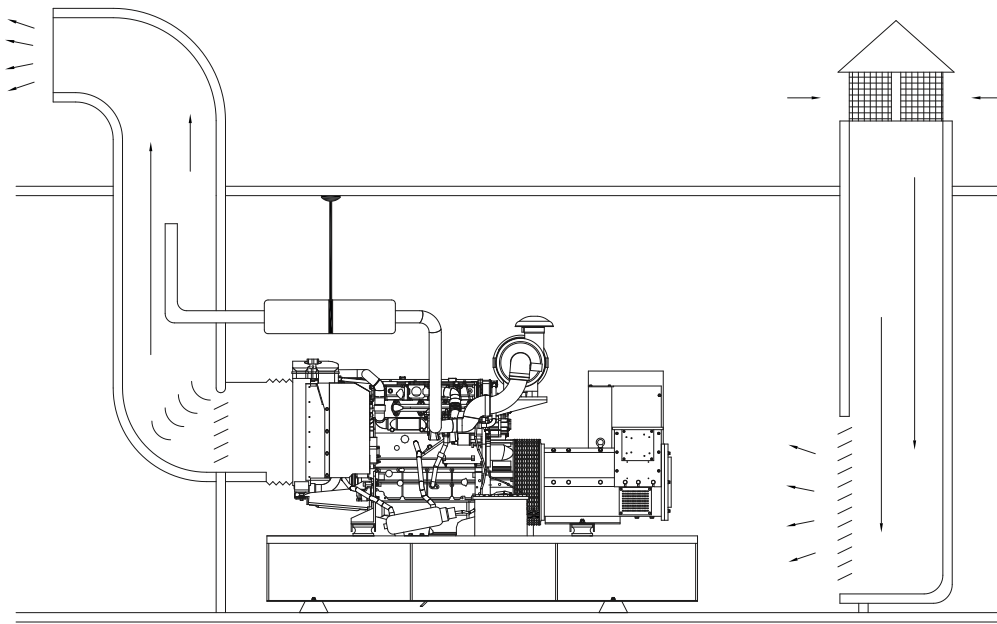

Figure-I / Generator minus elevation location plan

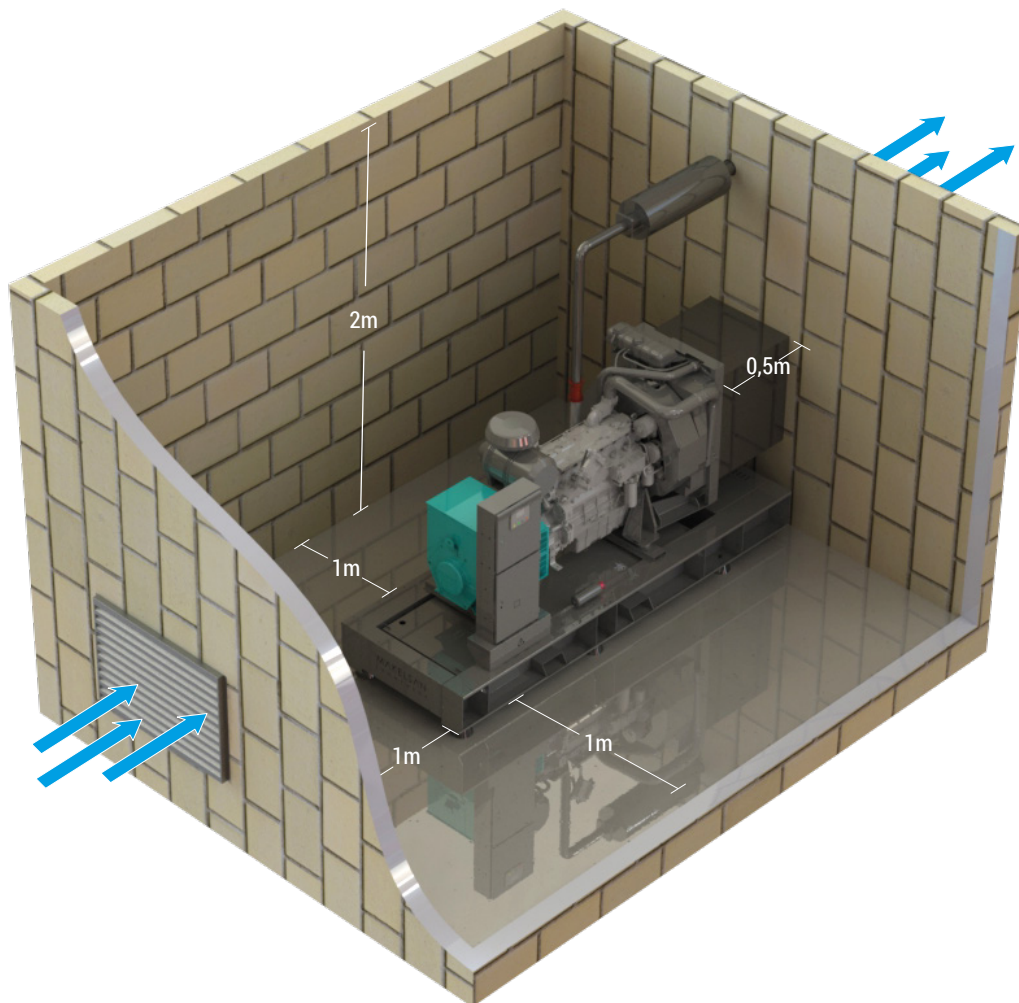

Figure-J / Generator base location plan

4 / LIFTING, PLACEMENT, INSTALLATION AND STORAGE

- To prevent rain from entering the open exhaust outlet, flap type counterweight rain covers should be used in different applications.
- Each generator must have its own exhaust system. Using a single exhaust pipe, the exhaust outlets of the generators cannot be combined. Otherwise, one generator will be subjected to pressure against the other generator, or a short circuit by-pass from the generator exhaust line running on the non-operating generator will occur.
- Exhaust installation material must be metal pipe.

4.14 FUEL SYSTEM

The fuel supply to the diesel engine may be provided in the following ways.

1. Directly from the fuel tank in the chassis
2. From the external fuel tank located outside the chassis

One of the most important issues for the diesel engine is the use of clean fuel that does not contain water and foreign matter. Dirt inside the fuel causes damage to the fuel injection system. The water in the fuel causes some parts of the fuel equipment to corrode.

FEATURES OF USED FUEL

Viscosity: 1,3-5,8 centistroke at 40°C for each second 1.3-5.8 mm

Cetane Number: Above 0°C min 40; Below 0°C min. 45

Amount of Sulfur: Not to exceed 0.5% by volume

Water and Sediment: Not to exceed 0.05% by volume

Density: 0,816 - 0,876 g/cc 15°C

Acid Amount: Not exceed 0,1MgKOH per 100ml

Lubrication: 3.100gr or higher

It is recommended to use Nu.2-D diesel fuel as fuel.

WARNINGS



- Generators' fuel storage systems must comply with the standards.
- Do not allow incidents such as flame, sparks or smoking around the fuel. Use warning signs.
- In applications using an external type fuel tank, more than one generator can be supplied from a single fuel tank. However, the fuel return lines from each generator must return separately from the coupling.
- Under the fuel tanks, overflow pan and leak warning systems should be applied to protect the environment in case of possible overflow and leakage.
- Even if the fuel in the fuel tank is drained, it should not be approached by fire or a welding operation should be carried out in the tank. The gas vapor to be left in the tank, which is discharged from the fuel, has a flammable and explosive characteristic and it must be provided "gas-free" to evacuate the remaining gas in the tank before possible welding.
- Do not use copper pipes between the fuel tank and the diesel engine. Use black steel pipe as fuel pipe. Do not use a metal, copper pipe or pvc pipe with a coating.
- For flexible connection, choose the fuel hose.

4.14.1 DAILY FUEL TANK

The daily fuel tank keeps the daily fuel needed by the generator ready for use. Therefore, the daily fuel tank in the generator room up to 6 mt.

at a distance. The steel frame of the generator is manufactured as a tank-chassis to store the daily fuel tank (except for 900 kVA or special applications).

Note: For larger powers or special applications, please contact see our representatives.

4.14.2 MAIN FUEL TANK

In addition to the daily fuel tank, the main fuel tank can be connected for longer operation of the generator.

The main fuel tank should be placed outside the room for convenient filling and maintenance. However, as the viscosity increases in cold environments, the main fuel tank should not be left in extreme cold environments as the fuel flow will be limited. An air vent (vent) must be installed on the fuel tank to reduce the air pressure generated during evaporation, expansion or fueling of the tank. This air outlet also prevents the formation of vacuum in the tank during fuel consumption. The bottom of the fuel tank must have a slope. Thus, water and sediment are collected at a point to prevent damage to the fuel system. A drain valve must be installed at the bottom of the fuel tank to drain water and sediment.

4.14.3 FUEL LINE

Fuel-compatible substances such as black steel pipes or flexible hoses resistant to environmental conditions can be used in fuel piping. Flexible fuel hoses must be connected between the engine and the fuel tank to avoid leakage and damage caused by engine vibration. The fuel supply line should receive fuel at least 10-50 mm above the bottom of the fuel tank and away from the fuel return line.

WARNINGS



- Use black steel pipe or flexible fittings for the fuel system.
- Do not fill the fuel tanks completely. Leave a space of 10% of the fuel tank capacity to allow the fuel to expand at high ambient temperatures.
- Fuel temperature is a critical factor for proper engine operation. As the fuel temperature above 71°C reduces the heat content per volume due to expansion, the engine output is reduced.
- The connecting pipe from the main fuel tank to the daily fuel tank must be greater than or equal to the daily tank supply pipe.
- Using a water separator prefilter on the fuel system line will protect the injectors and the fuel pump.
- The main fuel tank may be above or below the daily fuel tank.
- The daily fuel tank must not be further than 6m from the diesel engine fuel intake port.

4 / LIFTING, PLACEMENT, INSTALLATION AND STORAGE

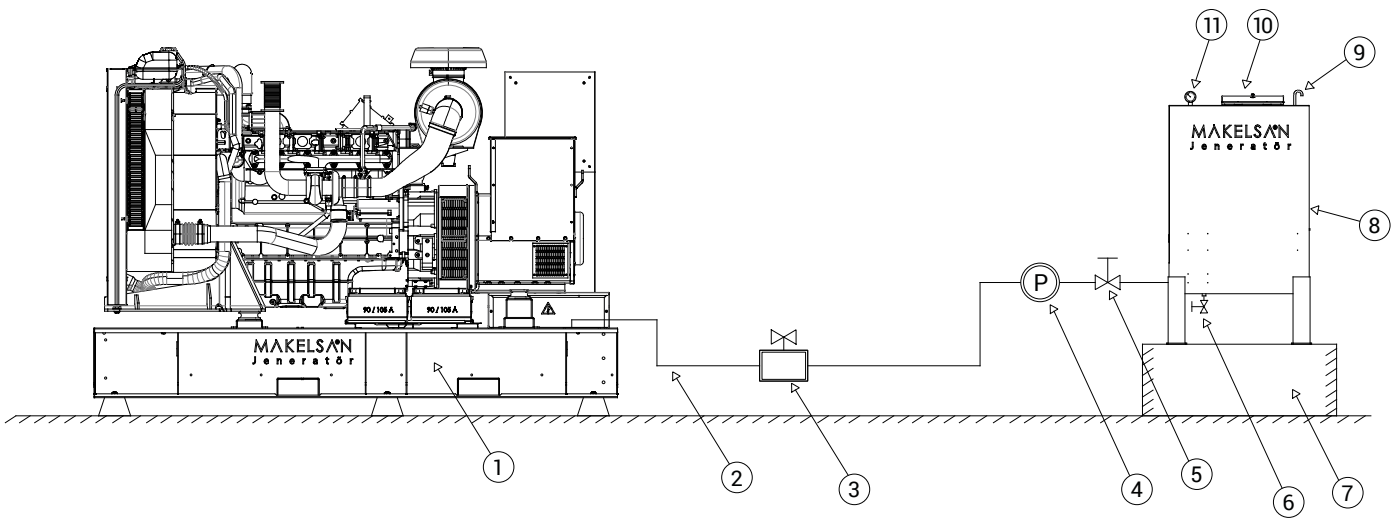

Figure-K / Typical general fuel piping installation from main fuel tank to daily fuel tank

- | | |
|---|------------------------------------|
| 1. Generator daily fuel tank in chassis | 7. Main fuel tank overflow pan |
| 2. Feed line to daily fuel tank | 8. Main fuel tank |
| 3. Electric fuel shutoff valve | 9. Weather |
| 4. Electric fuel transfer pump | 10. Main fuel tank filling cap |
| 5. Outlet valve | 11. Main fuel tank level indicator |
| 6. Drain valve | |

FUEL PIPE RECOMMENDATIONS				
GENSET POWER STAND BY (kVA)	MAX FUEL PIPE LENGTH (m)	MAXIMUM VERTICAL LENGTH (m)	MAX FITTING FEATURE QUANTITIES	RECOMMENDED PIPE DIAMETER ((inch)
0-800	6	0.9	6	1"
800-1500	6	0.9	6	1" 1/2"
1500-2200	6	0.9	6	2

Table 1. Table of recommended fuel installation pipe diameters

Positive static fuel pressure must be applied the fuel pump inlet at all times in fuel tank applications to be installed according to stand-by generator groups.

4 / LIFTING, PLACEMENT, INSTALLATION AND STORAGE

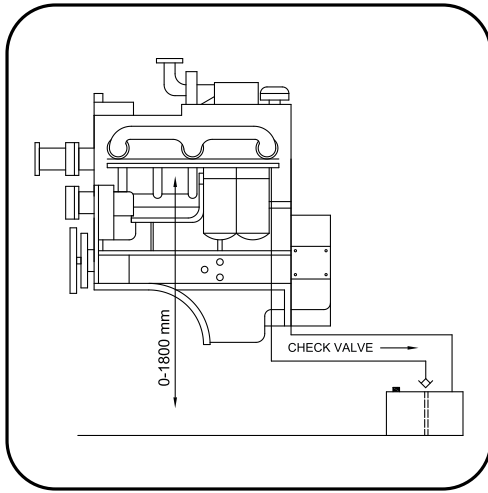

Figure-L1 / Typical fuel diagram with fuel tank placed below the engine

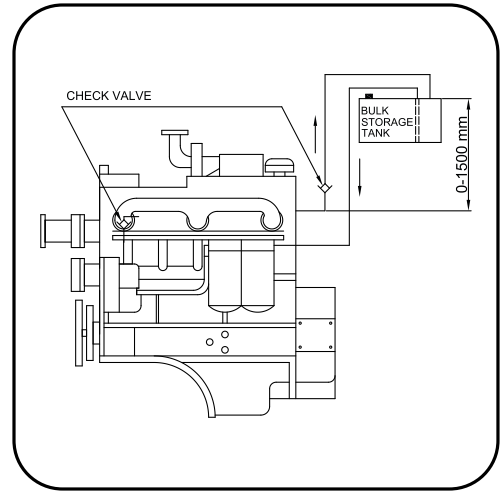

Figure-L2 / Fuel tank and check valve connection placed approximately 1500 mm above the fuel return

The height of the fuel tank is 2 m from the center of the crankshaft. check valves must be used. The maximum fuel gauge may not exceed 2m above the crankshaft center and the minimum fuel level must be at least 15cm above the fuel injection pump. If the fuel level exceeds 2m, engine damage may occur. If the fuel level is less than 15cm, proper fuel pressure will not be provided at the fuel pump inlet. In other words, the tank fuel level should not be higher than the injectors and no more than 180cm below the fuel pump. (Fig. L1)

If the fuel tank is raised from the injectors to a height of approx. 1.5m, additional 2 check valves (Fig. L2) are installed to protect the engine from hydraulic locking. The protection capacity of these valves is from 0 to 1.5m. If the fuel tank is above 1.5m, a float tank must be installed. The tank mounted far and high (Fig. L3) is also shown. The fuel tank (Fig. L4), which is placed far below the engine level, is also shown.

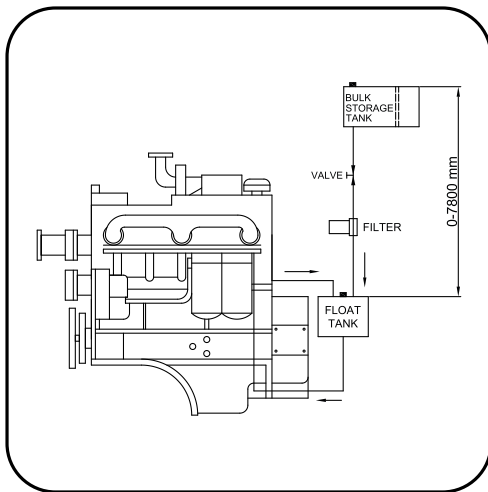

Figure-L3 / Float tank used with elevated fuel tank

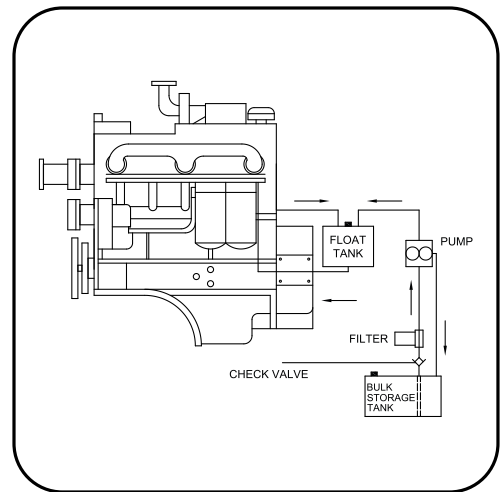

Figure-L4 / Fuel tank located lower than 1500 mm

4 / LIFTING, PLACEMENT, INSTALLATION AND STORAGE

4.15 ENGINE OIL AND COOLANT

The lubrication system of diesel engines is one of the most important parts of the engine. Proper engine maintenance (oil change periods, filter change periods and proper attention to the type of oil used) extends the life of the engine and reduces the cost of the engine.

Recommended engine oil; 15W / 40 Turbo Diesel

4.15.1 VISCOSITY-TEMPERATURE DIAGRAM

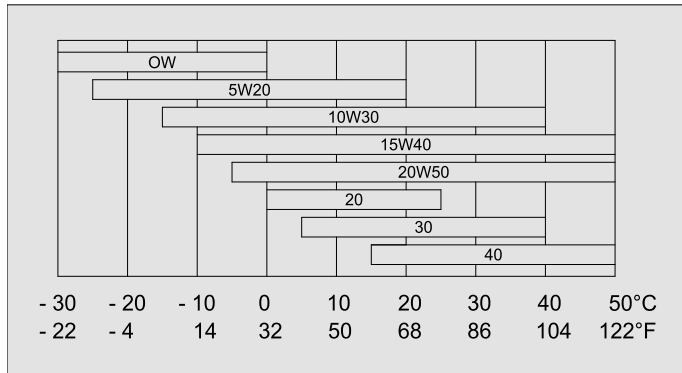

Figure-M / Viscosity-Temperature Diagram

The oil used is compatible with the temperatures in your area. You can check from the table next to.

Recommended Coolant; Pure Antifreeze

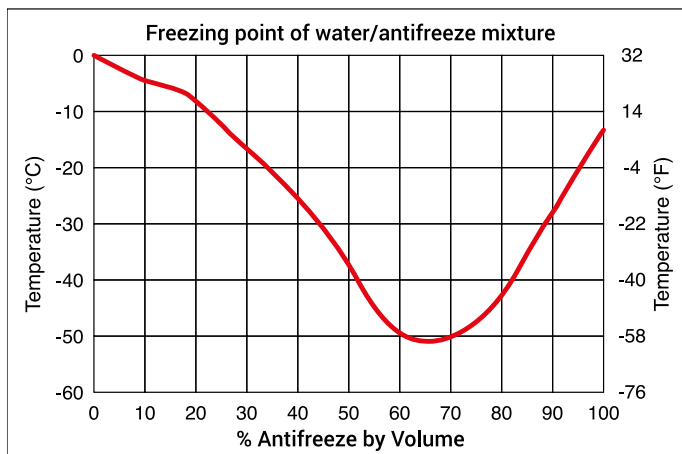

Figure-N / Water-Antifreeze Ratio Diagram

Antifreeze may not have been added to your generator's radiator at the factory. When adding coolant to your radiator, antifreeze must be added at a rate appropriate to the conditions of the region (50% on average). The use of antifreeze water in your engine in summer and winter is of great importance for the life of your engine and the cleanliness of water channels.

4.16 BATTERIES

4.16.1 MAINTENANCE TYPE BATTERIES

WARNINGS



- When connecting the battery, the last negative terminal must be connected, and when disconnecting the battery, the negative terminal must first be removed from the battery.
- Do not allow incidents such as flames, sparks, or smoking that may cause a fire.
- When preparing the battery, wear an acid resistant apron, face mask and safety goggles. If battery electrolyte is spilled onto the skin or clothing, immediately clean the spilled area with a large amount of

pressurized water.

- Before using conductive tools on the battery, remove items such as chains and rings from your hand and wrist.
- The water supply and battery maintenance should be performed outdoors.
- Batteries should be placed as close to the generator as possible. If batteries are placed away from the generator, it will cause voltage drop. This reduces the engine cranking capacity of the batteries.

4 / LIFTING, PLACEMENT, INSTALLATION AND STORAGE

4.16.1.1 CHARGING ACID WATER TO THE BATTERY

- Remove the protective cover from the battery covers.
- Remove the air flaps.
- Fill the battery up to 15 mm above the top of the plates with clean battery water with a specific gravity of 1,280 at 20°C. The battery and acid temperature must be above 10°C.
- Let the battery stand for 15 minutes. Then, the battery cells (pockets) will start to heat up and gas bubbles will rise to the surface of the electrolyte. Refit the air flaps.
- Wait at least 15 minutes and then check the battery with a hydrometer.
- The minimum charging time is 6 hours. Check the charge current and electrolyte level every 1 hour. Charged if no change was observed for 1 hour.
- Check the electrolyte level 2 hours after charging and, if necessary, add distilled water 10 mm above the plates.

4.16.1.2 BATTERY MAINTENANCE

- Keep the battery and terminals clean.
- Carefully coat the battery terminals and connections with grease.
- Tighten the terminals well.
- Check the electrolyte level regularly. The electrolyte level should always be 10 mm above the plates.
- Check the charge alternator belt regularly for wear and belt tension.
- Make sure that the battery is charged.

4.16.1.3 TESTING THE BATTERY

- Visually inspect the battery before testing.
- Oxidation of the battery terminals and terminals occurs over time. Oxidation erodes the battery terminals and prevents charging. Disconnect the connection and clean the oxide with boiling water. Then make the connection again and coat with petroleum jelly or grease.
- Do not allow loose connections.

4.16.1.4 HYDROMETER TEST

- The specific gravity and charge status of the sulfuric acid in the battery can be measured using a hydrometer.
- Do not add distilled water if the battery water level is low. Use only pure water.
- Hold the barrel of the hydrometer upright and pull up enough electrolyte.
- There should be free swimming in the tube. Reading should be done at eye level.
- The evaluation is as follows;

1.270	1,280	specific weight fully charged
1.220	1,230	specific weight semi-charged
1.150	1,220	specific weight discharged

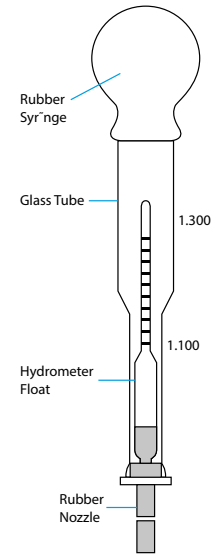

Figure-0 / Hydrometre

4.16.2 MAINTENANCE-FREE BATTERIES

Make sure that the batteries are not charged and that the electrical connections are correctly made. Furthermore, these batteries do not require any maintenance.

4.17 ELECTRICAL CONNECTIONS

The electrical connections and maintenance must be carried out by qualified, competent and experienced authorized services.

WARNINGS



- Make the electrical connections in accordance with the relevant electrical codes and standards.
- Make sure that the connected cables do not lean against the edges and corners and that insulation weakness or short circuit will not occur.
- Make the connections with the correct tightening / torque values.
- Insulate the connection area of the shoe and cable with heat shrink tubing. Do not use electrical tape.
- Do not add splices to the cable line.
- Electricity generation, transmission and distribution systems or use of the equipment may cause fire or electro shock.
- The personnel working in generator maintenance should stand on dry wooden platform or rubber insulated mat for protection and dry clothes and shoes.
- Do not lay cables on the floor of the generator room.
- Use separate conduits or pipes for electrical cables, fuel and water pipes.
- Use separate conduits or pipes for AC and DC cables.
- Ensure that the device is properly grounded.
- To prevent unintentional start-up of the genset during maintenance of the automatic genset, disconnect the battery and battery charger connections. Disconnect the battery charger from the AC supply before disconnecting the battery cables. Accidental operation of the generator

4 / LIFTING, PLACEMENT, INSTALLATION AND STORAGE

while working on the generator may result in personal injury or death.

- Do not release the electrical interlocks.
- Electrical connections must be made by a qualified technician. In particular, check that the cable connections have been made properly.
- Do not carry out maintenance and / or repairs on the energized appliance.

4.17.1 WIRING

- Due to the vibration on the generator, electrical connections should be made with flexible cables.
- The cables must be placed in the cable ducts and be of the cross section and type suitable for the generator output voltage and current.
- When deciding on the cable cross-section, tolerances should be given for conditions such as ambient temperature, location method, proximity to other cables. However, cables must be selected according to TSE or VDE standards.
- All connections must be checked for accuracy.
- Neutral conductors must either be dimensioned at high values or the cross-section of the neutral conductor must be at least in the cross-section of the phase conductor, since it is not possible to produce harmonics and estimate the quantity in the planning phase of the plant.
- When selecting a cable, one must be aware of the distance between the load and the generator and whether there are inrush loads (such as an electric motor).
- In low voltage networks, if the distance is too long, the voltage drop on the load side may drop to undesirable levels as the voltage drop will increase greatly during inrush. To prevent this, a more suitable cross-sectional load cable can be selected with the following formula.

$$\Delta U = \sqrt{3} \times L \times I \times (R \cos \varphi + X \sin \varphi)$$

ΔU = Absolute Voltage Drop (Volt)

L = Length of Line (m)

I = Line Current (A)

R = Resistance of Cable (ohm/m)

X = Reactance of the Cable (ohm/m)

In low voltage networks and if the distance is short;

if currency known, with $A = \frac{1,73 \cdot L \cdot I \cdot \cos \phi}{k \cdot \Delta U}$ formula

if the power known, $A = \frac{L \cdot P}{k \cdot \Delta U \cdot U}$ with the formula can be selected load cable of appropriate cross-section.

A = Line Section (mm²)

L = Line Length (m)

I = Line Current (A)

ΔU = % Voltage Decrease should not exceed 3% for Power Line)

k = Conductivity (For Copper k=56).

P = Power (W)

U = Voltage between Mains and Phases (V)

4.17.2 PROTECTION

The cables connected to the genset by the distribution system must be

protected by a circuit breaker that automatically disconnects in case of overload or short circuit.

4.17.3 INSTALLATION

It is very important to ensure a balanced load to the generator when planning the main distribution board in the facility where the generator will be installed. If the load in one phase is more than the load in the other phases, this will cause the alternator windings to overheat, the phase-to-phase output voltage is unbalanced and the sensitive three-phase devices connected to the system will be damaged. No phase current should exceed the rated current of the generator. In order to ensure that these loading conditions are met, the existing distribution system may be reorganized. The unbalanced load ratio should be $\pm 50\%$.

4.17.4 POWER FACTOR

If the power factor of the load is 0.8, the generator will deliver the specified power and operate properly. If the power factor of the load is less than 0.8, the generator is overloaded. Power factor correction elements such as capacitors can be used to correct this power factor. In such cases, however, the power factor correction elements must be deactivated when the generator is loaded. When determining the genset power, both the active and reactive powers must be calculated and the exact power must be determined.

4.17.5 GROUNDING / GROUNDING CONDITIONS

Malfunctions and damages that may occur in the isolation of electrical devices cause the parts of the devices not related to the energy system to remain under voltage other than the main current circuit. Occasionally, if the voltage level reaches extreme values, the insulation is punctured due to the device being exposed to puncture voltage, causing these insulating parts to remain under voltage. Grounding should be done in order to protect human life and devices.

What is expected from good grounding:

- Continuous and continuous
- Capable of carrying fault currents
- Low impedance sufficient to keep voltage drop to a limited level
- Low soil spreading resistance
- Soil specific resistance can be limited as small

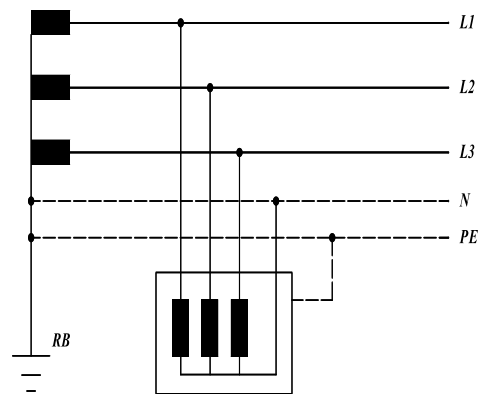

Figure-P / TN Type Mains

4 / LIFTING, PLACEMENT, INSTALLATION AND STORAGE

Electricity companies have different types of grounding as network types. Therefore, electricity companies in different parts of the world choose transmission and distribution power systems from TT, TN and IT systems.

TN type networks are the most widely used type of network today. In such networks, the star point of the network is grounded. The housings and metal parts of the devices are connected to the protective conductor PE. PE is also connected to the grounded part at the star point.

In the event of a phase-to-earth contact, the PE or PEN protection lines and the connected devices increase their ground voltage. The value of these voltages can provide the desired value, ie, below the permissible contact voltage, by keeping the RB resistor less than 2 ohms.

In the design of the grounding facility;

- The location of the grounding system is determined.
- Measurements are performed to determine soil specific resistance.
- The type of electrode to be used in the grounding is determined.
- The short circuit current of the plant and the tripping time of the protection elements to be connected to the system are determined.
- The spread resistance is calculated.
- Cross-section of earthing conductor.
- The accuracy of the selection and calculation values is checked.
- Step and contact voltages are calculated and the suitability of the system is investigated.

Before commissioning, all conductors and connection points are examined by hand and eye.

The ground resistance must be $R_t < 4$ ohms. If this value cannot be achieved, the soil resistance value should be made suitable by performing the above-mentioned operations again.

While grounding in the generator system; The most important issue to be considered is that the grounding areas for the mains ground and the generator should be at least 20 m apart. This distance is to prevent the earthing systems from being affected by each other.

In the grounding systems made with the most commonly used rod grounding devices, the lengths of the rod grounding devices used and the distances between them are important. In grounding systems with more than one bar grounding device, the distance between the bars should be at least two bars. In a grounding where a 1.5 m tall bar grounding device is used, the other rod shall be driven at least 3 m away from the first tapped rod.

The generator housing must be particularly earthed. The earth connection must be flexible to prevent breaks due to vibration. The grounding cables must meet the standards and be capable of carrying at least the full load current.

4.17.6 PARALLEL OPERATION

Additional equipment will be required to operate one generator in parallel with other generators or mains. For such special applications, please contact our authorized sales representatives.

4.17.7 INSULATION TEST

If your generator is idle for a long time, insulation test should be performed. If the generator is idle for a long time, test the insulation resistance of the windings before starting. At the same time, all control connections must be disconnected from the Automatic Voltage Regulator (AVR). Rotating diodes must also be short-circuited or disconnected. A 500 V Megger or similar instrument can be used. Connect the megger between the output terminal and ground (chassis). The insulation resistance must be greater than 1 M with respect to the ground. If the insulation resistance is less than 1 M, the alternator windings must be dried.

Insulation testing should only be carried out by qualified and authorized technicians.

4.18 SOUND ABSORBERS

It is increasingly important to control the noise of generators in the settling areas that are getting crowded with each passing day. Various equipment is available to control the sound level of the generator. For such special applications, please contact our authorized sales representatives.

4.19 TRAILER TYPE GENERATORS

4.19.1 PREPARATION

All fasteners on the towing vehicle and the trailer generator must be checked for loose nuts, bent metal, cracks, abrasion. Check the condition of all tires. Check that all flash lamps and headlamps are working.

4.19.2 TOWING

When towing the trailer generator, remember that the weight of the trailer will affect the maneuver and stopping distance.

WARNINGS



- All traffic rules, standards and other regulations must be observed when towing the trailer generator. This includes the necessary equipment and speed limits that are expressly specified in the regulations.
- Do not allow personnel to travel on a mobile generator.
- Do not allow personnel to stand on the towbar or between the mobile generator and the towing vehicle.
- Avoid slopes and soft terrain and obstacles such as pits and stones.
- When maneuvering backwards, make sure that the floor behind and under the mobile generator is clean.

4.19.3 PARKING SPACE

Park the trailer generator on a dry surface that can lift its weight. If parking on a slope, park on a slope to avoid slipping down and use chocks. Do not park above 15°.

4 / LIFTING, PLACEMENT, INSTALLATION AND STORAGE

4.20 STORAGE

Long-term storage of the engine and alternator for more than 6 months can have harmful effects. These effects can be minimized by properly preparing and storing the generator. In order to receive the necessary support, support from the authorized services must be obtained.

4.20.1 STORING THE ENGINE

An engine protection procedure, including engine cleaning and protective fluids, may be applied to the engine. Contact your dealer.

4.20.2 STORING THE ALTERNATOR

Moisture builds up in the windings when the alternator is stored. To reduce this humidity, store the generator in a dry place. Warm air if possible to keep windings dry. The alternator, which has not been used for a long time, must be tested for insulation before use. (See 4.17.7)

4.20.3 STORING THE BATTERY

When storing, the battery must be checked every 8 weeks and fully charged if necessary. There are battery chargers in automatic generators. Optional for manual generators.

4.21 ENGINE BLOCK WATER HEATER

Block (jacket) water heater is used to start the engine quickly and to take over the load. The heater heats the block water of the engine when the generator is not running. The heater must therefore be switched on in all seasons. There is a block water heater in the automatically activated generators. Optional for manual generators. Circulating pump heaters are also optional.

5 / DIESEL ENGINE MAINTENANCE

A good maintenance program will extend the life of your generator and ensure that you receive the most effective service during this lifetime. The periodic maintenance schedule is given to the generator at which times and what maintenance should be performed. All necessary

interventions should only be carried out by authorized service centers. In general, the generator should always be kept clean. Do not allow substances such as water, fuel and oil to accumulate on or in the generator. Always keep the generator floor and surrounding area clean.

6 / CONTROL SYSTEMS

Electronic control systems are used to control and monitor the operation of the generator. The control / control panel basically provides the starting, stopping, operating status and output voltage of the

generator. It also automatically shuts down the generator in case of low oil pressure, high engine temperature and various fault conditions.

7 / STARTING THE GENERATOR

7.1 GENERAL INTRODUCTION

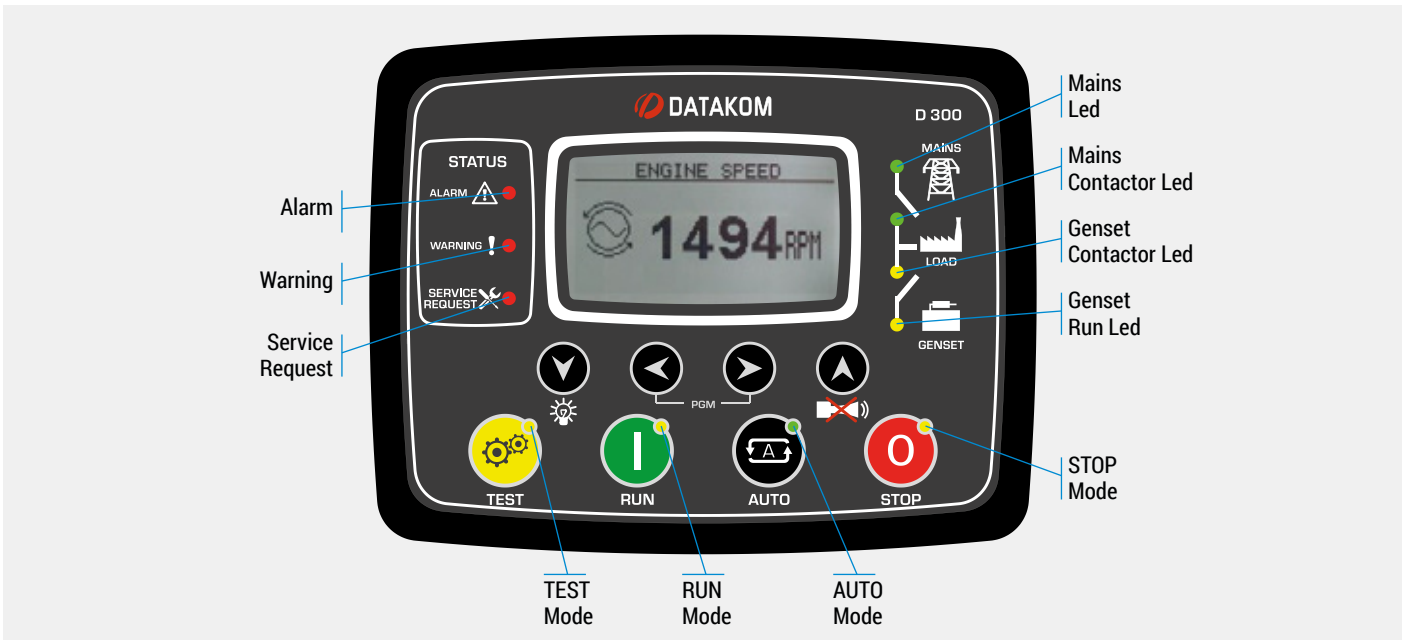

Figure-R / Control Panel Overview

STATUS LEDS

ALARM: This LED lights up if an alarm or load shedding occurs.

WARNING: This LED lights up if a warning condition occurs.

SERVICE TIME: If one of the service counters expires, this LED will light.

MODE LEDS: LED is on when device or remote mode is selected.

MAINS AND GENERATOR LEDS

MAINS YES: This LED is on if mains phase voltages and frequency are between limits. If the mains phase sequence control is activated from the program parameters, the phase sequence must also be correct. If one of the digital inputs is set to Remote Run, this LED will reflect the status of the input. If a Simulate Network signal is applied to the device, the network is assumed to be present. If the Switch to Run Mode input is applied to the device, the network is ignored.

MAINS CONTACTOR: This LED lights up when the mains contactor is energized.

GENSET CONTACTOR: This LED lights up when the generator contactor is energized.

GENERATOR ON: This LED is on if the genset phase voltages and frequency are between limits. If the generator phase sequence control is activated, the phase sequence must also be correct.

7 / STARTING THE GENERATOR

7.2 OPERATION MODES

STOP: Press  the STOP button.

OPERATING: Press  the RUN button.

LOAD TEST: Press  TEST button. The generator is activated and takes over the load.

AUTOMATIC OPERATION: Press  AUTO button. Make sure that the AUTO READY LED is lit.

The mode can be changed at any time. This has no negative effect on the device. If the mode is changed while the generator is running, the device will move according to the new operation mode.

7.2.1 AUTOMATIC OPERATION

 Button should be pressed for AUTO Mode.

AUTO Mode provides automatic switching between mains and generator. The device monitors the network values. If the device sees the network as non-existent, it starts the generator and provides load transfer.

Assuming the network exists:

- If the voltage or frequency of at least one of the mains phases exceeds the programmed values, the mains will be ignored.
- If the Network Simulation input is applied, the network is assumed to be present.
- If the Switch to Run Mode signal is applied, the network is ignored.
- If the Remote Start input is defined on the device, the network status is determined according to this signal. Ignoring the mains and starting the generator:
- If the Engine Run Delay parameter is set on the device, the device waits for this period to prevent unnecessary activation of the generator during short mains interruptions. If the mains values return to normal within this period, the genset will not start.
- The contact output of the device is activated and if the pre-heating time is set in the program parameters, the device waits for this time.
- The engine cranks for the set start time. When the engine starts, the starter output is immediately interrupted. For detailed information, please refer to the cranking section.
- The engine runs at idle for the set time.
- The genset turns off the rated circuit and runs without load for the engine heating time.
- If the genset phase voltages, frequency and phase sequence are correct, then the genset contactor is waited for the genset contactor time and the genset contactor is energized. Restoring the grid and stopping the generator.
- Mains voltage is stable; the generator will continue to run for the mains standby time.
- At the end of this period, the generator contactor opens and the mains contactor is energized at the end of the mains contactor period.
- If the cooling time is set in the unit, the genset will continue to run idle for this time.
- The device reduces engine speed to idle before the end of the cooling time.
- At the end of the cooling time, the ignition output is cut off and the

stop solenoid output is energized during the stop solenoid time, the engine stops.

- The device will wait ready for the next mains failure.

7.2.2 MANUAL OPERATION

 Pressing the button switches the device to manual operation. When the RUN key is pressed, the genset will start regardless of the mains. The operation of the generator shall be as follows:

- The contact output of the device is activated and if the pre-heating time is set in the program parameters, the device waits for this time.
- The engine cranks for the set start time. The starter output cuts off when the engine starts. For detailed information, please refer to the cranking section.
- The engine runs at idle for the set time.
- The genset runs without load until another mode is selected.
- The load can be transferred to the genset by switching to test mode.

7.2.3 TEST OPERATION AT LOAD

 Press the button to switch the device to the test position. The TEST mode is used to test the generator under load. When the device is put into the test mode, the genset starts and the load is transferred from the mains to the genset as described in AUTO mode by ignoring the mains. The genset continues to feed the load until another mode is selected on the device.

7.3 PROTECTIONS AND ALARMS

The device has 3 levels of protection; alarms, alerts, and load throws.

1- ALARMS: These are the most important errors and cause the following actions:

- The ALARM led lights steadily,
- The generator releases the contactor immediately,
- The engine stops immediately,
- The alarm output is energized.

2- LOAD ATMs: These errors lead to the following actions:

- The ALARM led lights steadily,
- The generator releases the contactor immediately,
- The engine stops after cooling operation,
- The alarm output is energized.

3- WARNINGS: These errors cause the following actions:

- WARNING led lights steadily,
- The alarm output is energized.

 If an error condition occurs, the ALARM LIST page is automatically displayed.

 Press the HORN SILENCE button to release the ALARM relay. This key does not eliminate alarms.



Alarms on the device can be cleared by pressing any of the control buttons.

7 / STARTING THE GENERATOR

7.4 MAINTENANCE

To clean the device, wipe it with a soft damp cloth, do not use chemicals.

7.5 OPERATING CONDITIONS

It is important that the load distribution in the phases is balanced in both manual and automatic controlled generators to ensure trouble-free operation of your generator. It is the responsibility of the user to

ensure that the load distribution between the phases remains within the tolerance values of $\pm 15\%$.

The generator must be protected from sudden and de-massed loads. Otherwise it will be possible to encounter important faults in diesel engine and alternator.

Malfunctions due to inadequate and / or incomplete maintenance or neglect are not covered by the warranty.

8 / LOCATION AND PLACEMENT OF POWER TRANSFER PANEL (PTP)

The points to be considered in the placement of PTP;

- Install the PTP as close to the main distribution board as possible. This will allow you to complete your installation work at minimum cost.
- Ensure that the selected installation area is clean, dry, well ventilated and away from excessive heat.
- Sufficient working space should be left around the PTP for all interventions after installation. The cover of the PTP should be easily opened and easily intervened.
- Information about the current carrying of the power cables to be used for the generators is given in 4.13.1.
- The operation connection must be made correctly for the generator to function properly. This connection method is shown in (Figure-S). There are two cable entries to the panel. One is the mains input for the control of the network and the other is the output of the generator. The mains line received from the meter output or the compensation board, if any, is supplied to the receiver via the mains contactor. The issue to be considered here; the generator is connected after the meter.

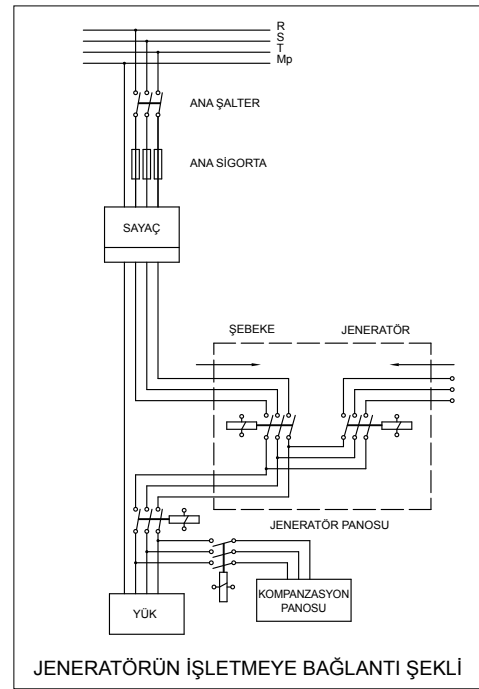

Figure-S

9 / ALTERNATOR TROUBLE SHOOTINGS

FAULT SYMPTOM: ALTERNATOR DOES NOT PRODUCE VOLTAGE

REASON:

- Loss of residual magnetism in the stator windings.
Solution (a): If the alternator is winding, connect the +, - terminals to the same terminals of the 9.5 V dry battery for 5 sec. contact.
- Non-contact in panel or terminal connections.
Solution (b): Open the panel cover and check that there is no protrusion on the cable ends and that there is no protrusion on the terminal ends.
- The warning button has broken.
Solution (c): Check all connections, in particular the alternator terminal block connections.
- Rotary diodes are defective.
Solution (d): Test the diodes one by one with the diode test part of the Avometer and replace the defective diodes.

e) Drive speed is too low.

Solution (e): Increase the speed of the drive to the nominal.

f) The regulator board is faulty.

Solution (f): Replace the non-regulating card.

FAULT SYMPTOM: VOLTAGE DROPS AS ALTERNATOR LOADS

REASON:

- The regulator board is defective.
Solution (a): Set the output voltage to 400 V with the regulator potentiometer in idle mode. If the voltage drops as it loads after this adjustment, replace the card.
- Drive machine speed drop too high.
Solution (b): Check the drive power.

9 / ALTERNATOR TROUBLE SHOOTINGS

c) The alternator is loaded on power.
Solution (c): Do not load above rated.

d) Rotating diodes are defective.
Solution (d): Check the diodes with the AVO meter. Replace any faults.

FAULT SYMPTOM: VOLTAGE RISES AS ALTERNATOR LOADS

REASON:
a) The motor is reversed.
Solution (a): Move the generator output cables.

FAULT SYMPTOM: GENERATOR VOLTAGE TOO HIGH

REASON:
a) One of the phase-seeing ends of the regulator is broken.
Solution (a): Check the terminal connections.
b) There is a break in the voltage adjustment potentiometer.
Solution (b): Check potentiometer leads.
c) The regulator board is defective.
Solution (c): Replace the non-regulating card.
d) Load between phases is unstable.
Solution (d): Perform load balancing

FAULT SYMPTOM: ONE OR TWO VOLTAGE IS NOT READ

REASON:
a) There is a break in the voltage control commutator terminals.
Solution (a): Check commutator terminals.
b) Stator windings are broken.

Solution (b): Open the terminal box cover and lift the star connection bridge. Check for a break or short circuit between the windings.

FAULT SYMPTOM: WRAPPING IS HEATING EXTREMELY

REASON:
a) The genset is loaded above rated.
Solution (a): Operate at rated load.
b) There may be a short circuit between the windings.
Solution (b): Check the short-circuit between the windings in the terminal box.

FAULT SYMPTOM: GENERATOR OUTPUT VOLTAGE WIPES

REASON:
a) The regulator board does not regulate.
Solution (a): Replace the regulator board.
b) Windings are shorted.
Solution (b): Open the terminal box and check the windings with the Avometer. If there is a resistance difference, there is a short circuit.
c) One or more of the bridge diodes are faulty.
Solution (c): Replace the faulty diodes.

10 / DIESEL ENGINE TROUBLE SHOOTINGS

FAULT SYMPTOM: STARTER DIESEL TURNS SLOWLY

REASON:
a) Battery uncharged
b) Poor contact with battery cables
c) Starter motor defective
d) Lubricating oil viscosity degree is incorrect

FAULT SYMPTOM: OIL PRESSURE VERY LOW

REASON:
a) Fat viscosity degree is incorrect
b) Not enough oil in the crankcase
c) Pressure gauge faulty
d) Oil filter dirty

FAULT SYMPTOM: BLUE OR WHITE EXHAUST SMOKE

REASON:
a) Fat viscosity degree is incorrect
b) defective heater
c) Diesel engine cold
d) Valve misalignment
e) Fuel advance adjustment defective

FAULT SYMPTOM: DIESEL ENGINE HARD OR NOT WORKING

REASON:
a) The starter cannot rotate with diesel
b) Air in the fuel circuit
c) Fuel tank is empty
d) Fuel pipe blocked
e) The fuel control solenoid is faulty
f) Fuel filter is dirty

10 / DIESEL ENGINE TROUBLE SHOOTINGS

- g) Heater not working
 - h) Exhaust pipe is blocked
 - i) Poor quality fuel
 - j) Fuel tank vent blocked
 - k) Fuel pre-pump is defective
 - l) Injectors defective or incorrectly adjusted
 - m) Oil sensor / switch or connection defective
-

FAULT SYMPTOM: OIL PRESSURE TOO HIGH

REASON:

- a) Fat viscosity degree is incorrect
 - b) Oil pressure gauge faulty
-

FAULT SYMPTOM: ENGINE DOES NOT ENOUGH POWER

REASON:

- a) Fuel pipe clogged
 - b) Fuel filter dirty
 - c) The air filter is dirty
 - d) Air in fuel system
 - e) Poor quality fuel
 - f) Exhaust pipe blocked
 - g) Fuel pre-pump malfunction
 - h) Governor defective
 - i) High engine temperature
 - j) Low engine temperature
 - k) Injector defective or incorrect setting
 - l) Fuel tank ventilation blocked
 - m) Fuel advance adjustment defective
 - n) Valve out of adjustment
-

FAULT SYMPTOM: ENGINE RUNS ERROR

REASON:

- a) Fuel pipe clogged
 - b) Fuel governor defective
 - c) Fuel filter dirty
 - d) Fuel pump defective
 - e) The air filter is dirty
 - f) Air in fuel system
 - g) Injectors defective or incorrectly adjusted
 - h) Fuel tank vent blocked
 - i) Valve settings are defective
 - j) Engine temperature too high
 - l) Heater system defective
 - m) There is resistance in fuel governor movement
-

FAULT SYMPTOM: MOTOR TEMPERATURE TOO HIGH

REASON:

- a) Exhaust pipe blocked
-

- b) Cooling fan damaged
 - c) Radiator cores dirty or blocked in pipe
 - d) Insufficient air circulation
 - e) Air filter or pipe clogged
 - f) Injectors defective or incorrectly adjusted
 - g) Heater system defective
 - h) Low oil level in crankcase
 - i) Insufficient cooling water level
-

FAULT SYMPTOM: CARTRIDGE PRESSURE HIGH

REASON:

- a) Crankcase ventilation pipe clogged
 - b) Valve misalignment (worn from piston ring and liner)
-

FAULT SYMPTOM: FIRING (STARTING BUT NOT WORKING)

REASON:

- a) Fuel pipe clogged
 - b) Fuel filter dirty
 - c) Air in fuel system
 - d) Fuel pump defective
 - e) Engine temperature too low
 - f) Incorrect valve settings
 - g) Injector defective or incorrect setting
 - h) Heater defective
 - i) Oil sensor / switch or connection faulty
-

FAULT SYMPTOM: ENGINE BOTTOM

REASON:

- a) Injector malfunction or misalignment
 - b) Valve settings incorrect
 - c) Fuel pump malfunction
 - d) Poor quality fuel
 - e) Engine temperature too low
 - f) Heater system defective
-

FAULT SYMPTOM: MORE FUEL CONSUMPTION

REASON:

- a) The air filter is dirty
 - b) Fuel of poor quality
 - c) Exhaust pipe blocked
 - d) Heater system defective
 - e) Valve settings incorrect
 - f) Engine temperature too low
 - g) Injector defective or incorrect setting
-

10 / DIESEL ENGINE TROUBLE SHOOTINGS

FAULT SYMPTOM: EXHAUST GAS BLACK

REASON:

- a) The air filter is dirty
 - b) Motor overloaded
 - c) Fuel poor quality
 - d) Exhaust pipe blocked
 - e) Engine temperature too low
 - f) Valve settings incorrect
 - g) Injector defective or misaligned
-

FAULT SYMPTOM: VIBRATED WORK

REASON:

- a) Fan is damaged
 - b) Difficulty in fuel governor movement
 - c) Injector defective or incorrectly adjusted
 - d) Engine temperature too low
 - e) Valve settings incorrect
-

FAULT SYMPTOM: ENGINE STOPPING AFTER STARTING

REASON:

- a) Air in the fuel system
 - b) Fuel filter dirty
 - c) Air filter or suction system blocked
 - d) Oil sensor / switch or connection faulty
 - e) Stop solenoid holding coil defective
-

Datrotef Generator, which has a total of 1000 working hours guarantee with a limit of 500 working hours per year or 2 years, pay attention to the following issues in order to ensure that the warranty of the generator is not broken, that it can produce trouble-free service and has a long service life!

Warranty start date is the invoice date of Datrotef Generator and is limited to 2 years or 500 working hours per year and 1000 hours in total whichever comes first.

If the guarantee certificate or invoice is not presented, the transactions will not be covered by the warranty.

If any person interferes with the generator for any reason other than Datrotef Generator authorized services, the generator will be out of warranty.

The checks and maintenance specified in the maintenance instructions must be performed in a timely and complete manner. Failure to do so will be excluded from the warranty.

The maintenance schedule and maintenance manuals of the generator are delivered to the customer together with the generator. In the event that the maintenance booklet and schedule are lost, the customer is obliged to provide these booklets again.

During the installation process of the generator, the instructions specified in the operating instructions must be followed. Failure to do so will be excluded from the warranty.

The customer shall be responsible for any faults arising from the use of dirty, aqueous fuel which does not comply with the standards or caused by the freezing of the fuel. Such defects shall not be covered by the warranty.

Lubricating oil selection must be made in accordance with the criteria specified in the operating instructions. Failure to do so will be excluded from the warranty.

The battery / batteries you have purchased together with the generator group; breakage, excess acid, uncharged and hardened in case of warranty is excluded. The warranty certificates of the batteries are sent with the generator and in case of any failure, assistance will be obtained from the battery manufacturer.

For manual type generators, do not start or stop your generator under load. Start and stop operation must be performed with the generator unloaded after the load has been disconnected. Otherwise, faults that may occur in diesel engine and alternator will be out of warranty.

Datrotef Generator guarantee will not be valid for damages caused by unbalanced load, overcurrent, low and high voltage that will occur in parts such as mains contactors, block water heaters, battery charging rectifiers used in automatic type generator groups and operating under mains energy.

Datrotef Generator warranty will not be valid in case of silencer installation de-assembled generators, in case the silencer is not installed on time, opening of safety covers, entering water from exhaust line due to inadequate silencer or exhaust installation.

If there is not enough fuel in the fuel tank, your generator will not work due to the air in the fuel system after the fuel supply to be made after the initial commissioning of the genset without being supplied to the fuel tank. In this case, Datrotef generator guarantee will not be valid for the service needs that will occur.

The commissioning of the purchased generator will be performed free of charge by Datrotef Generator authorized services after you declare that you have completed the preparations for commissioning. At the end of the service to be provided, it is determined that one or more of the preparations for commissioning have not been made and if the commissioning is not completed, you will have to pay the service fee in advance to the authorized service of Datrotef Generator for the next commissioning service.

The commissioning process by checking the operating conditions of the generator (placement, installation, electrical connections, cable cross-sections, ventilation, exhaust outlet, fuel path etc.) is only valid for the place where the commissioning process is performed and the electrical connections are made. If it is desired to change the place where the first start operation is made, since the working conditions of the genset will be changed depending on the environment, the generator should be checked and commissioned again by Datrotef Genset authorized service for the continuation of the genset operation and guarantee period. For the second commissioning service, you will have to pay the service fee in advance to the authorized service of Datrotef Generator.

The customer shall cover all maintenance, breakdowns and problems except for manufacturing defects.

Malfunctions resulting from negligence, failures occurring from the time of receipt of the delivery to the first commissioning process, misuse, including the responsibility for downloading are under the responsibility of the customer.

If the received generator is not to be commissioned within 6 months, it must be kept on condition that it provides storage conditions. You can get the necessary information and help regarding the storage conditions of your generator from Datrotef Generator Authorized Services. It is obligatory that the conservation process of a generator within the warranty period be carried out by Datrotef Generator Authorized Services.

If the service provider providing overtime work is required by the customer, the customer will bear the cost of overtime.

11 / WARRANTY TERMS AND CUSTOMER'S RESPONSIBILITIES

Inlets, barriers, walls, fences, floors, ceilings, decks, or similar structures, leased cranes or the like, ramps or the like, towers or protective structures constructed to reach the generator, in the complete reception or connection of the generator fees incurred shall be borne by the customer.

The customer has the right to ask and investigate the authority of the personnel coming for service. This is also the customer's duty.

The customer is responsible for any failure in the cooling system where chemicals are not added to the cylinder liner or block to prevent tingling, erosion and deposits.

During the warranty period of your generator, the original equipment and the project can not be made in addition to equipment and projects. If the additional works planned to be performed (synchronous, additional control unit, panel, transfer panel etc.) are performed by a company other than Datrofel Generator or without the approval of Datrofel Generator, Datrofel Generator warranty will expire.

Datrofel Generator original spare parts must be used in all generators under warranty.

Datrofel Generator is not liable for any faults that may be caused by drawing more current than the generator rated current through the mains contactor selected according to the generator power.

The failures in the generator due to natural disasters or environmental effects such as earthquakes, floods, floods and the like are not covered by the warranty.

In our automatic type generators, the upper and lower limits of the mains are determined based on the values that our generator and the customer's enterprise can operate in a healthy manner. If change of the mains voltage limits is requested, this change can be made non-warranty and paid by writing the report that the customer assumes all responsibility for the failures caused by this change.

12 / CUSTOMER SERVICE

In order to meet the uninterrupted energy requirement, Datrofel Generator is always with you to provide the best service for all its customers by keeping the customer satisfaction at the highest level for 7/24.

13 / MAINTENANCE INSTRUCTION

TIME TABLE FOR MAINTENANCE														
BY OPERATION	OPERATING TIME												WORKING ITEMS	
	Every Day	Every Months	Every 6 Months	Every 12 Months	50 hour	150 hour	300 hour	500 hour	1000 hour	2000 hour	5000 hour	10000 hour		
User Operator	+													Check to Lubrication Oil Level
User Operator	+													Check to Cooling Water Level
User Operator	+													Check to Fuel Tank Level
User Operator		+												Rinse the Exterior of Diesel Engine
User Operator		+			+									Check to Engine Block Temperature
User Operator		+												Drain Oil Fuel Unit to Come Qualified Fuel
User Operator		+			+									Run Test Mode and Listen to Unseven Voice
By Qualified Service					+	+	+	Every 150 Hours					Re-Tighten the Connecting Bolt and Cylinder Head Bolt (20kgf)	
By Qualified Service					+	+	+	Every 150 Hours					Check the Belt and Tension	
By Qualified Service					+	+	+	Every 150 Hours					Change to Oil Level of Fuel Injection Pump (If have this System)	
By Qualified Service							+	Check to Indicator					Change Lub. Oil and Lub. Oil Filter (Use 15W40 Turbo Diesel Oil)	
By Qualified Service								+						Clean Up or Renewed to Air Filter
By Qualified Service					+	+	+	Every 150 Hours					Check Valve Clearance	
By Qualified Service								+						Check Fuel Filter Element
By Qualified Service									+					Clean Up the Crankcase Ventilation Mechanism
By Qualified Service										+				Check to Fuel Injectors
By Qualified Service								+	+					Check to Compressive Pressure
By Qualified Service									+		+			Check to Bearing Clearance of the Water Pump
By Qualified Service									+		+			Check to Super Charger
By Qualified Service											+			Check to Fuel Injection Pump
By Qualified Service											+			Check Cylinder Head
By Qualified Service												+		Check Cylinder Liner
By Qualified Service													+	Check the Water Jacket Space
By Qualified Service													+	Check Connecting Rod and Main Bearing
By Qualified Service													+	Check Piston
By Qualified Service													+	Check Crank Shaft
By Qualified Service													+	Check Camshaft
By Qualified Service													+	Check Drive Gear
By Qualified Service									+		+	+		Overhaul Fuel Injection Pump
By Qualified Service													+	Change Oil Pump
By Qualified Service											+	+		Change the Oil Sealing of the Crankshaft
By Qualified Service											+			Change to the Ball Bearing of Alternator
By Qualified Service					+					+				Drain Oil Cooling Water and Add Water and Corrosion Preventive

If the running time does not reach 50 hours after 6 months, the required maintenance procedure must be carried out during this period
 If the running time does not reach 150 hours after 12 months, the required maintenance procedure of this period must be carried out during this period

POWER WITH YOU



DATROFEL ENERJİ VE TEKNOLOJİ SAN. A.Ş.

Address: Halkapınar Mah. 1348. Sk. 2 AE Keremoğlu   Merk. Yenişehir - Izmir / Turkey

T: +90 (232) 469 47 00 **F:** +90 (232) 449 47 00 **E:** info@datrofel.com.tr

www.datrofel.com.tr